

**JMA**<sup>®</sup>  
FRANCE

CLES ADAPTABLES  
CLES A POMPE ET TYPE MUEL  
CLES POUR ASCENSEURS  
CLES POUR BOITES AUX LETTRES  
CLES POUR MEUBLES  
CLES POUR COFFRES-FORTS

*LEADER EN TECHNOLOGIE*

*LEADER EN QUALITE*

*LEADER EN ENGAGEMENT  
ENVIRONNEMENTAL*

*LEADER EN SERVICE*

**PAL** SERVICE  
MINUTE

Tél. 04 73 84 84 94

**CATALOGUE CLES A GORGES**

**A3** *Texte légal*

**A4** *JMA France / JMA dans le monde*

**A5** *JMA le leader*

**A6 - A9** *La passion de la clé*

*Clés pour cylindres et voitures  
Clés personnalisées  
Clés crystal  
Clés extralégères  
Clés colomatic  
Clés fashion  
Clés de voitures tête plastique antichocs  
Clés de voitures tête antichocs pour insertion puce*

**A10 - A13** *Machines à reproduire les clés*

**A14** *Technologie transpondeur*

**A15** *Description et terminologie*

**A16 - A29** *INDEX*

**A17 - A25** *Index général*

**A27-A29** *Index par marques*

**01 - 61** *TYPES DE CLES*

**01-04** *Clés à pompe françaises et type Muel*

**05-10** *Clés adaptables à gorges et à chiffres en laiton*

**12-25** *Clés à gorges et à chiffres par marque de serrure*

**26-46** *Clés adaptables à gorges et à chiffres en fonte et en acier*

**48-51** *Clés de style pour meubles*

**52-53** *Clés pour ascenseurs et boîtes aux lettres*

**54-58** *Clés pour coffres-forts français*

**60-61** *Clés spéciales*



Tél. 04 73 84 84 94

## CLES POUR CYLINDRES ET VOITURES

En acier nickelé, en laiton ou alpaca.



## CLES PERSONNALISEES

En acier nickelé. Avec les coordonnées du reproducteur sur une ou deux faces en tête unique pour différentes références.



## CLES CRYSTAL

En 5 couleurs assorties: bleu, jaune, orange, rouge et vert.  
Références disponibles: CA-4I, CI-DL, RO-10D, RO-29D, TE-8I, U-5D, U-5I, VA-8D.  
Nb.: Ajouter les lettres "CA" à la référence de la clé.  
Par exemple: CI-DLCA.



## CLES EXTRALEGERES

En 5 couleurs: bleu (B), jaune (J), rouge (R), vert (V), violet (VI).  
Références disponibles: BRI-19, CA-6D, CE-5D, CI-DL, CA-4I, JPM-2I, RO-10D, RO-29D, TE-8I, U-5I, U-5D, VA-8D.  
Nb.: Ajouter la lettre "E" et la lettre indiquant la couleur à la référence de la clé.  
Exemple: BRI-19EB



# LA PASSION DE LA CLE

## CLES COLORMATIC

En 5 couleurs assorties : bleu, jaune, orange, rouge et vert

Références disponibles:

BRI-19, CA-4I, CA-6D, CI-6DI, CI-DL, CI-6I (CI-IL), JPM-2I, RO-10D, RO-29D, TE-8I, U-15 (U-5I), U-15D (U-5D), VA-36, VA-8D.

Nb. : ajouter les lettres "MA" à la référence de la clé.  
Par exemple: BRI-19MA



## CLES FASHION

- des couleurs surprenantes

- 24 motifs joyeux et modernes, réactualisés dans le temps afin de continuer à proposer de nouveaux dessins et de nouvelles couleurs

- références disponibles:  
CA-4IFA, CI-DLFA, RO-10DFA, TE-BIFA, U-5DFA, VA-8DFA



## CLES DE VOITURES TETE PLASTIQUE ANTICHOCS

Une gamme très étendue respectant les formes de tête originales



## CLES DE VOITURES TETE ANTICHOCS POUR INSERTION PUCE

Clés fournies vierges permettant d'accueillir toutes les puces de la marque JMA.

Nb. : Brochure complète fournie sur demande.



**01-04**

*CLES A POMPE FRANÇAISES ET TYPE MUEL*



**05-10**

*CLES ADAPTABLES A GORGES ET A CHIFFRES EN LAITON*



**12-25**

*CLES A GORGES ET A CHIFFRES PAR MARQUE DE SERRURE*

*En laiton, fonte, acier et zamak*



**26-46**

*CLES ADAPTABLES A GORGES ET A CHIFFRES EN FONTE ET EN ACIER*



# LA PASSION DE LA CLE

48-51

CLES DE STYLE POUR MEUBLES



52-53

CLES POUR ASCENSEURS ET BOITES AUX LETTRES

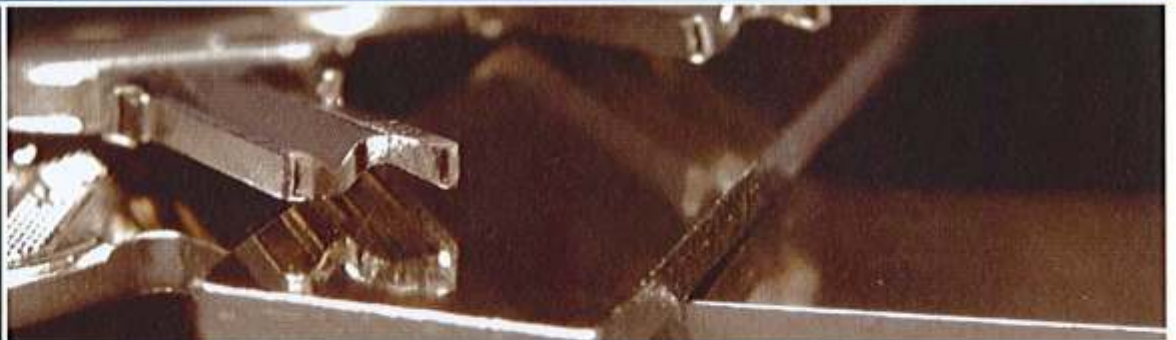

54-58

CLES POUR COFFRES-FORTS FRANÇAIS



60-61

CLES SPECIALES



**THE KEY TO EXCELLENCE**  
GLOBALLY UNLOCKING MILLIONS OF DOORS DAILY

# DESCRIPTION ET TERMINOLOGIE

- 1 TETE
- 2 COU
- 3 DIAMETRE DE LA TIGE
- 4 TIGE
- 5 LONGUEUR
- 6 PANNETON
- 7 PROFIL MALE
- 8 REFERENCE
- 9 MARQUE ORIGINALE
- 10 CLE FOREE

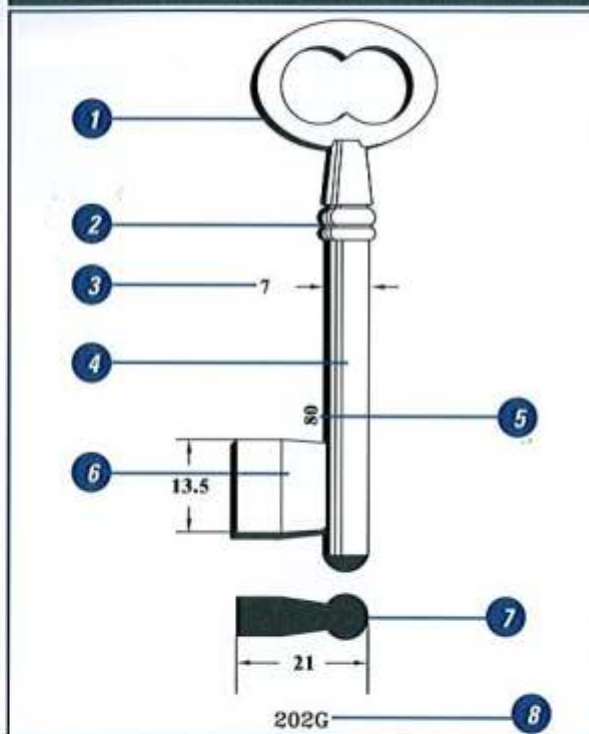

## 9 — ORENGO

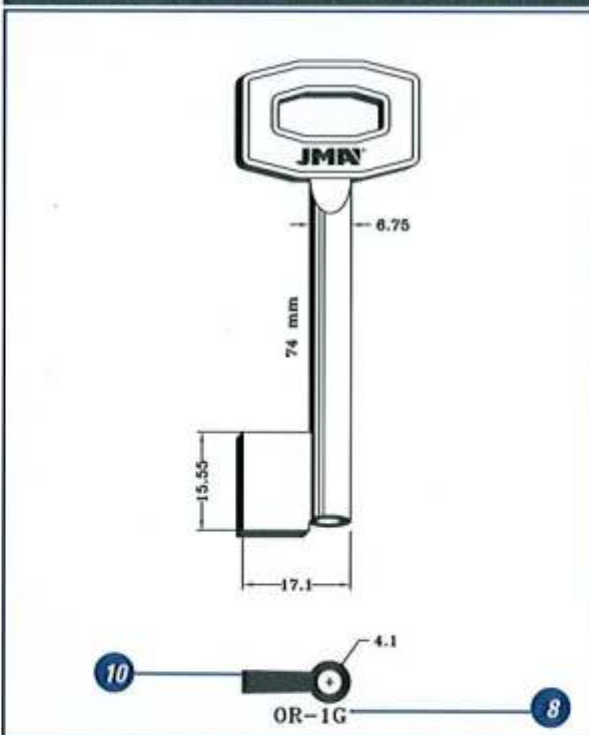

# ***INDEX GENERAL***



***THE KEY TO EXCELLENCE***  
GLOBALLY UNLOCKING MILLIONS OF DOORS DAILY

**CLÉS A POMPES FRANÇAISES ET TYPE MUEL / CLÉS ADAPTABLES A GORGES ET A CHIFFRES / CLÉS A GORGES ET A CHIFFRES PAR MARQUE DE SERRURE / CLÉS DE STYLE POUR MEUBLES / CLÉS POUR ASCENSEURS ET BOÎTES AUX LETTRES / CLÉS POUR COFFRES-FORTS FRANÇAIS / CLÉS SPECIALES**

REF.	PAG.	PAG.
21G	43	
25G	32	
74G	18	

## A

A-3G	51	143
A-3G(CV)	51	143
AA-3G	51	
AA-3G(CV)	51	143
AC-3	53	143
AC-4	53	
AC-7	53	
AC-8	53	
AC-9	53	
AD-1	7	
AD-1F	13	143
AD-2	7	143
AD-2F	13	143
AD-3	7	143
AD-3F	13	
AD-4	7	143
AD-4F	13	143
AD-5	7	
AD-5F	13	
AD-6	7	
AD-6F1	13	
AD-6F2	13	
AD-6F3	13	
AD-6F4	13	
AD-6F5	13	
AD-6F6	13	
AD-7	7	
AD-7F	14	
AD-8	7	
AD-9	7	
AD-9F	14	
AD-9T	8	
AD-10	7	
AD-10T	8	
AD-11	7	
AD-11F	14	
AD-11T	8	
AD-12	7	
AD-12T	8	
AD-13	7	
AD-13F	14	
AD-13T	8	
AD-14F	14	
AD-16	7	
AD-16F	14	
AD-17	7	
AD-18	7	
AD-18F	14	

REF.	PAG.	PAG.
AD-19	7	
AD-20	7	
AD-20F	14	
AD-21	7	
AD-21F	14	
AD-23	7	
AD-23F	14	
AD-24	7	
AD-25	7	
AD-25F	14	
AD-26	7	
AD-27	7	
AD-27F	14	
AD-28	7	
AD-28F	14	
AD-29	7	143
AD-29F	14	143
AD-31F	14	143
AD-33F	14	143
AD-33T	8	143
AD-34F	14	
AD-35F	14	
AD-36F	14	
AD-37F	14	
AD-38F	14	
AD-40F	14	
AD-41F	14	
AD-42F	14	
AD-43F	14	
AD-45	7-43	
AD-46	8	
AD-47	8	
ADPLE-11	9	
ADPLE-22	9	
ADPLE-33	9	
ADPLE-44	9	143
ADPLE-55	9	143
ANGL-3	21	
ANGL-3T	21	
ANGL-4	21	
ANGL-4T	21	
ANGL-5	21	
ANGL-5T	21	
ANGL-6	21	
ANGL-6T	21	
ANGL-7	21	
ANGL-7T	21	
ANGL-8	21	
ANGL-8T	21	
ANGL-9	21	
ANGL-9T	21	
ANGL-10	21	
ANGL-10T	21	
ANGL-11	21	

REF.	PAG.	PAG.
ANGL-11T	21	
ANGL-12	21	
ANGL-12T	21	
ARM-1T	14	
ARM-2F1	14	
ARM-2F2	14	
ARM-2F3	14	
ARM-2F4	14	
ARM-2F5	14	
ARM-2F6	14	
ART-1	49	
ART-2	49	
ART-3	49	143
ART-4	49	143
ART-5	49	
ART-12B	49	
ART-12R	49	
ART-13B	49	
ART-13R	49	
ART-PAL	49	

## B

B-3G	50	
B-3G(CV)	50	
BAU-1	16	
BEC-14F	15	
BED-1F	16	
BET-14F	15	
BOE-1	27	
BRI-1	27	
BRI-1X	27	
BRI-2	27	
BRI-2X	27	
BRI-3	27	
BRI-3X	27	
BRI-4X	27	
BRI-5F1	28	
BRI-5F2	28	
BRI-5F3	28	
BRI-5F4	28	
BRI-5F17	28	
BRI-5F18	28	
BRI-5F21	28	
BRI-5F22	28	
BRI-5F29	28	
BRI-5F30	28	
BRI-5F83	28	
BRI-5F84	28	
BRI-5X	27	
BRI-6L1	28	
BRI-6L2	28	
BRI-6L7	28	
BRI-6L8	28	

REF.	PAG.	PAG.
BRI-6L11	28	
BRI-6L12	28	
BRI-6L17	28	
BRI-6L18	28	
BRI-6L21	28	
BRI-6L22	28	
BRI-6L29	28	
BRI-6L30	28	
BRI-6X	27	
BRI-6XB1	27	
BRI-6XB2	27	
BRI-6XB3	27	
BRI-6XB4	27	

## C

C-3G	50	
C-3G(CV)	50	
CA-1E	1	
CAV-1F1	17	
CAV-1F2	17	
CAV-1F3	17	
CAV-1F4	17	
CAV-1F5	17	
CAV-1F6	17	
CAV-1F7	17	
CAV-1F8	17	
CAV-1F9	17	
CAV-1F10	17	
CAV-1F11	17	
CAV-1F12	17	
CAV-1F21	17	
CAV-1F22	17	
CAV-1F23	17	
CAV-1F24	17	
CAV-1F29	17	
CAV-1F30	17	
CAV-1F35	17	
CAV-1F36	17	
CAV-1F37	17	
CAV-1F38	17	
CAV-1F43	17	
CAV-1F44	17	
CAV-1F49	17	
CAV-1F50	17	
CAV-1F63	17	
CAV-1F64	17	
CAV-1F69	17	
CAV-1F70	17	
CAV-1F75	17	
CAV-1F76	17	
CAV-1F77	17	
CAV-1F78	17	
CAV-1F81	17	

# INDEX GENERAL

REF.	PAG.	PAG.
CAV-1F82	17	
CHU-4G	27	
COF-12T	58	
COLL-2	15	
COLL-3	15	
COLL-4	15	
COLL-5	15	
COLL-6	15	
COLL-7	15	
COLL-8	15	
COM-11T	19	
COM-2T	19	
COM-3T	19	
COM-4T	19	
COM-5T	19	
COM-6T	19	
COM-7T	19	
COM-8T	19	
COM-9T	19	
COM-10T	19	
COM-11T	19	
COM-12T	19	
COM-13T	19	
COM-14T	19	
COM-15T	19	
COM-16T	19	
COM-17T	19	
COM-18T	19	
CRE-1	18	
CRE-2	18	
CRE-3	18	
CRE-4	18	
CRE-5	18	
CRE-6	18	
CRE-7	18	
CRE-8	18	
CRE-9	18	
CRE-10	18	
CRE-11	18	
CRE-12	18	
CRE-13	18	
CRE-14	18	
CRE-15	18	
CRE-16	18	
CRE-17	18	
CRE-18	18	
CRE-19T	18	
CRE-20T	18	

## D

DA-1	31	
DEB-1	28	
DEB-3	28	
DEB-4F1	29	
DEB-4F2	29	
DEB-4F3	29	
DEB-4F4	29	
DEB-4F5	29	
DEB-4F6	29	

REF.	PAG.	PAG.
DEB-4F7	29	
DEB-4F8	29	
DEB-4F29	29	
DEB-4F30	29	
DEB-4F37	29	
DEB-4F38	29	
DEB-4F43	29	
DEB-4F44	29	
DEB-4F49	29	
DEB-4F50	29	
DEB-5CL10	29	
DEB-5CL18	29	
DEB-5CL19	29	
DEB-5CL20	29	
DEB-5CL29	29	
DEB-5CL30	29	
DEB-5L1	30	
DEB-5L2	30	
DEB-5L3	30	
DEB-5L4	30	
DEB-5L5	30	
DEB-5L6	30	
DEB-5L7	30	
DEB-5L8	30	
DEB-5L9	30	
DEB-5L10	30	
DEB-5L11	30	
DEB-5L12	30	
DEB-5L17	30	
DEB-5L18	30	
DEB-5L19	30	
DEB-5L20	30	
DEB-5L21	30	
DEB-5L22	30	
DEB-5L27	30	
DEB-5L28	30	
DEB-5L29	30	
DEB-5L30	30	
DEB-5L63	30	
DEB-5L64	30	
DEB-5L73	30	
DEB-5L74	30	
DEB-5L75	30	
DEB-5L76	30	
DEB-5L79	30	
DEB-5L80	30	
DEB-6F1	30	
DEB-6F2	30	
DEB-6F3	30	
DEB-6F4	30	
DEB-6F23	30	
DEB-6F24	30	
DEB-6F29	30	
DEB-6F30	30	
DEB-6F31	30	
DEB-6F32	30	
DEB-6F75	30	
DEB-6F76	30	
DEB-7F1	31	
DEB-7F2	31	

REF.	PAG.	PAG.
DEB-7F3	31	
DEB-7F4	31	
DEB-7F9	31	
DEB-7F10	31	
DEB-10F1	31	
DEB-10F2	31	
DEB-10F3	31	
DEB-10F4	31	
DEB-11F1	31	
DEB-11F2	31	
DEB-11F3	31	
DEB-11F4	31	
DEB-11F5	31	
DEB-11F6	31	
DEB-11F57	31	
DEB-11F58	31	
DEB-11F75	31	
DEB-11F76	31	
DEB-12L	31	
DEN-1	32	
DEN-2	32	
DUC-1	55	
DUC-2	55	

## E

E-3G	51	
E-3G(CV)	51	

## F

FIC-1E	1	
FIC-1NS	55	
FIC-1X	56	
FIC-2E	1	
FIC-2H	32	
FIC-2NS	55	
FIC-2X	56	
FIC-3E	1	
FIC-3NS	55	
FIC-3X	56	
FIC-4H	32	
FIC-4X	56	
FIC-5H	32	
FIC-5X	56	
FIC-6X	56	
FIC-7X	56	
FIC-8X	56	
FIC-9X	56	
FIC-10X	56	
FIC-11X	57	
FIC-12X	57	
FIC-13X	57	
FIC-15X	57	
FIC-16X	57	
FIC-17X	57	
FIC-100	32	
FIC-200	32	
FIC-300	32	
FIC-400	33	
FIC-401G	33	

REF.	PAG.	PAG.
FON-1E	3	
FON-2E	3	
FON-3E	3	
FON-4E	3	
FON-5E	3	
FON-6E	3	
FTH-2L1	33	
FTH-2L2	33	
FTH-2L3	33	
FTH-2L4	33	
FTH-2L5	33	
FTH-2L6	33	
FTH-321	34	
FTH-322	34	
FTH-323	34	
FTH-324	34	
FTH-325	34	
FTH-326	34	

## G

GOLL-1	34	
GOLL-2	34	
GOLL-3	34	
GOLL-4	34	
GTV-1F1	35	
GTV-1F2	35	
GTV-1F9	35	
GTV-1F10	35	
GTV-1F13	35	
GTV-1F14	35	
GTV-1F15	35	
GTV-1F16	35	
GTV-1F19	35	
GTV-1F20	35	
GTV-1F21	35	
GTV-1F22	35	
GTV-1F31	35	
GTV-1F32	35	
GTV-1F37	35	
GTV-1F38	35	
GTV-1F41	35	
GTV-1F42	35	
GTV-1F45	35	
GTV-1F46	35	
GTV-1F53	35	
GTV-1F54	35	
GTV-1F55	35	
GTV-1F56	35	
GTV-1F57	35	
GTV-1F58	35	
GTV-1F61	35	
GTV-1F62	35	
GTV-1F63	35	
GTV-1F64	35	
GTV-1F67	35	
GTV-1F68	35	
GTV-1F69	35	
GTV-1F70	35	
GTV-1F75	35	
GTV-1F76	35	

REF.	PAG.	PAG.
GTV-1F 81	35	
GTV-1F 82	35	
GTV-1F 85	35	
GTV-1F 86	35	
GTV-1F 91	35	
GTV-1F 92	35	
GTV-1F 95	35	
GTV-1F 96	35	
GTV-1F 97	35	
GTV-1F 98	35	
GTV-1F 99	35	
GTV-1F100	35	
GTV-1F101	35	
GTV-1F102	35	
GTV-1F105	35	
GTV-1F106	35	
GTV-1F109	35	
GTV-1F110	35	
GTV-1F111	35	
GTV-1F112	35	
GTV-1F115	35	
GTV-1F116	35	
GTV-1F121	35	
GTV-1F122	35	
GTV-1F143	35	
GTV-1F144	35	
GTV-1F145	35	
GTV-1F146	35	
GTV-1F157	35	
GTV-1F158	35	
GTV-1F161	35	
GTV-1F162	35	
GTV-1F167	35	
GTV-1F168	35	
GTV-1F171	35	
GTV-1F172	35	
GTV-1F173	35	
GTV-1F174	35	
GTV-1F179	35	
GTV-1F180	35	
GTV-1F183	35	
GTV-1F184	35	
GTV-1F215	35	
GTV-1F216	35	
GTV-1F217	35	
GTV-1F218	35	
GTV-1F233	35	
GTV-1F234	35	
GTV-1F235	35	
GTV-1F236	35	
GTV-1F245	35	
GTV-1F246	35	
GTV-1F249	35	
GTV-1F250	35	
GTV-1F251	35	
GTV-1F252	35	
GTV-1F263	35	

REF.	PAG.	PAG.
GTV-1F264	35	
GTV-1F271	35	
GTV-1F272	35	
GTV-1F273	35	
GTV-1F274	35	
GTV-1F275	35	
GTV-1F276	35	
GTV-1F285	35	
GTV-1F286	35	
GTV-1F287	35	
GTV-1F288	35	
GTV-2F 1	36	
GTV-2F 2	36	
GTV-2F 9	36	
GTV-2F 10	36	
GTV-2F 11	36	
GTV-2F 12	36	
GTV-2F 13	36	
GTV-2F 14	36	
GTV-2F 15	36	
GTV-2F 16	36	
GTV-2F 19	36	
GTV-2F 20	36	
GTV-2F 21	36	
GTV-2F 22	36	
GTV-2F 35	36	
GTV-2F 36	36	
GTV-2F 37	36	
GTV-2F 38	36	
GTV-2F 41	36	
GTV-2F 42	36	
GTV-2F 45	36	
GTV-2F 46	36	
GTV-2F 47	36	
GTV-2F 48	36	
GTV-2F 49	36	
GTV-2F 50	36	
GTV-2F 51	36	
GTV-2F 52	36	
GTV-2F 53	36	
GTV-2F 54	36	
GTV-2F 55	36	
GTV-2F 56	36	
GTV-2F 57	36	
GTV-2F 58	36	
GTV-2F 63	36	
GTV-2F 64	36	
GTV-2F 67	36	
GTV-2F 68	36	
GTV-2F 69	36	
GTV-2F 70	36	
GTV-2F 75	36	
GTV-2F 76	36	
GTV-2F 81	36	
GTV-2F 82	36	
GTV-2F 85	36	
GTV-2F 86	36	

REF.	PAG.	PAG.
GTV-2F 95	36	
GTV-2F 96	36	
GTV-2F 99	36	
GTV-2F100	36	
GTV-2F109	36	
GTV-2F110	36	
GTV-2F111	36	
GTV-2F112	36	
GTV-2F121	36	
GTV-2F122	36	
GTV-2F143	36	
GTV-2F144	36	
GTV-2F147	36	
GTV-2F148	36	
GTV-2F161	36	
GTV-2F162	36	
GTV-2F173	36	
GTV-2F174	36	
GTV-2F179	36	
GTV-2F180	36	
GTV-2F183	36	
GTV-2F184	36	
GTV-2F215	36	
GTV-2F216	36	
GTV-2F217	36	
GTV-2F218	36	
GTV-2F235	36	
GTV-2F236	36	
GTV-2F249	36	
GTV-2F250	36	
GTV-2F263	36	
GTV-2F264	36	
GTV-2F275	36	
GTV-2F276	36	

## H

H-3G	50
H-3G(CV)	50

## J

J-1G(CV)	50
J-2G(CV)	50
J-3G	51
J-3G(CV)	51
JP-1	37
JP-1EC	1
JP-2	37
JP-2EC	1
JP-3	37
JP-4	37
JP-5	37
JP-6	37
JP-8L 1	37
JP-8L 2	37
JP-8L 3	37

REF.	PAG.	PAG.
JP-8L 4	37	
JP-8L 5	37	
JP-8L 6	37	
JP-8L 7	37	
JP-8L 8	37	
JP-8L 9	37	
JP-8L10	37	
JP-8L11	37	
JP-8L12	37	
JP-9Z 1	38	
JP-9Z 2	38	
JP-9Z 3	38	
JP-9Z 4	38	
JP-9Z 5	38	
JP-9Z 6	38	
JP-9Z 7	38	
JP-9Z 8	38	
JP-9Z 9	38	
JP-9Z10	38	
JP-9Z11	38	
JP-9Z12	38	

## K

KIM-1F 1	38
KIM-1F 2	38
KIM-1F 3	38
KIM-1F 4	38
KIM-1F 5	38
KIM-1F 6	38
KIM-1F 7	38
KIM-1F 8	38
KIM-1F 9	38
KIM-1F10	38
KIM-1F11	38
KIM-1F12	38
KIM-1F13	38
KIM-1F14	38
KIM-1F15	38
KIM-1F16	38
KIM-1F17	38
KIM-1F18	38
KIM-1F19	38
KIM-1F20	38
KIM-1F21	38
KIM-1F22	38
KIM-1F23	38
KIM-1F24	38
KIM-1F25	38
KIM-1F26	38
KIM-1F27	38
KIM-1F28	38
KIM-1F29	38
KIM-1F30	38
KIM-1F31	38
KIM-1F32	38
KIM-1F33	38

# INDEX GENERAL

REF.	PAG.	PAG.
KIM-1F34	38	
KIM-1F35	38	
KIM-1F36	38	
KIM-1F37	38	
KIM-1F38	38	
KIM-1F39	38	
KIM-1F40	38	
KIM-1F41	38	
KIM-1F42	38	
KIM-1F43	38	
KIM-1F44	38	
KIM-1F45	38	
KIM-1F46	38	
KIM-1F47	38	
KIM-1F48	38	
KIM-1F49	38	
KIM-1F50	38	

## L

L-3G	51	
L-3G(CV)	51	
LAP- 2E	1	
LAP- 3	28-39	
LAP- 3-3	28-39	
LAP- 3-4	28-39	
LAP- 3-5	28-39	
LAP- 3-6	28-39	
LAP- 3-9	28-39	
LAP- 3-10	28-39	
LAP- 3E	1	
LAP- 4F 1	39	
LAP- 4F 2	39	
LAP- 4F 3	39	
LAP- 4F 4	39	
LAP- 4F 5	39	
LAP- 4F 6	39	
LAP- 4F 9	39	
LAP- 4F10	39	
LAP- 4F13	39	
LAP- 4F14	39	
LAP- 4F27	39	
LAP- 4F28	39	
LAP- 5F 1	39	
LAP- 5F 2	39	
LAP- 5F 3	39	
LAP- 5F 4	39	
LAP- 5F 7	39	
LAP- 5F 8	39	
LAP- 5F 9	39	
LAP- 5F10	39	
LAP- 5F11	39	
LAP- 5F19	39	
LAP- 5F20	39	
LAP- 5F25	39	
LAP- 5F26	39	
LAP-100	39	
LAU-1Z 1	40	

REF.	PAG.	PAG.
LAU-1Z 2	40	
LAU-1Z 3	40	
LAU-1Z 4	40	
LAU-1Z 5	40	
LAU-1Z 6	40	
LAU-1Z 7	40	
LAU-1Z 8	40	
LAU-1Z 9	40	
LAU-1Z10	40	
LAU-1Z11	40	
LAU-1Z12	40	
LAU-1Z13	40	
LAU-1Z14	40	
LAU-1Z15	40	
LAU-1Z16	40	
LAU-1Z17	40	
LAU-1Z18	40	
LAU-1Z19	40	
LAU-1Z20	40	
LAU-1Z21	40	
LAU-1Z22	40	
LAU-1Z23	40	
LAU-1Z24	40	
LEG-1ZB1	40	
LEG-1ZB2	40	
LEG-1ZB3	40	
LEG-1ZB4	40	
LEG-1ZB5	40	
LEG-1ZB6	40	

## M

MAF-1	40	
MAF-2F 1	40	
MAF-2F 2	40	
MAF-2F 3	40	
MAF-2F 4	40	
MAF-2F 5	40	
MAF-2F 6	40	
MAF-2F 9	40	
MAF-2F10	40	
MAF-2F13	40	
MAF-2F14	40	
MAF-2F23	40	
MAF-2F24	40	
MG-6SCEL	61	
MNT-1T	18	
MNT-2T	18	
MOR-1X	42	
MOR-2X	42	
MRM-2Z 1	41	
MRM-2Z 2	41	
MRM-2Z 3	41	
MRM-2Z 4	41	
MRM-2Z 5	41	
MRM-2Z 6	41	
MRM-2Z 7	41	
MRM-2Z 8	41	

REF.	PAG.	PAG.
MRM-2Z 9	41	
MRM-2Z10	41	
MRM-2Z11	41	
MRM-2Z12	41	
MRM-2Z13	41	
MRM-2Z14	41	
MRM-2Z15	41	
MRM-2Z16	41	
MRM-3Z 1	41	
MRM-3Z 2	41	
MRM-3Z 3	41	
MRM-3Z 4	41	
MRM-3Z 5	41	
MRM-3Z 6	41	
MRM-3Z 7	41	
MRM-3Z 8	41	
MRM-3Z 9	41	
MRM-3Z10	41	
MRM-3Z11	41	
MRM-3Z12	41	
MRM-3Z13	41	
MRM-3Z14	41	
MRM-3Z15	41	
MRM-3Z16	41	
MRM-4Z 1	41	
MRM-4Z 2	41	
MRM-4Z 3	41	
MRM-4Z 4	41	
MRM-4Z 5	41	
MRM-4Z 6	41	
MRM-4Z 7	41	
MRM-4Z 8	41	
MRM-4Z 9	41	
MRM-4Z10	41	
MRM-4Z11	41	
MRM-4Z12	41	
MRM-4Z13	41	
MRM-4Z14	41	
MRM-4Z15	41	
MRM-4Z16	41	
MRM-5Z 1	41	
MRM-5Z 2	41	
MRM-5Z 3	41	
MRM-5Z 4	41	
MRM-5Z 5	41	
MRM-5Z 6	41	
MRM-5Z 7	41	
MRM-5Z 8	41	
MRM-5Z 9	41	
MRM-5Z10	41	
MRM-5Z11	41	
MRM-5Z12	41	
MRM-5Z13	41	
MRM-5Z14	41	
MRM-5Z15	41	
MRM-5Z16	41	
MUE- 1	53	

REF.	PAG.	PAG.
MUE- 1L	42	
MUE- 2	53	
MUE- 5 1-7	2	
MUE- 5 2-8	2	
MUE- 5 3-9	2	
MUE- 5 4-10	2	
MUE- 5 5-11	2	
MUE- 5 6-12	2	
MUE- 5 13	2	
MUE-16 0	2	
MUE-16 1	2	
MUE-16 2	2	
MUE-16 3	2	
MUE-16 4	2	
MUE-16 5	2	
MUE-16 6	2	
MUE-17 0	2	
MUE-17 1	2	
MUE-17 2	2	
MUE-17 3	2	
MUE-17 4	2	
MUE-17 5	2	
MUE-17 6	2	
MUE-17 7	2	
MUE-18 4	2	
MUE-18 5	2	
MUE-20 1	3	
MUE-20 2	3	
MUE-20 3	3	
MUE-20 4	3	
MUE-20 5	3	
MUE-20 6	3	
MUE-20 7	3	
MUE-20 8	3	
MUE-20 9	3	
MUE-20 10	3	
MUSE- 3	21	
MUSE- 3T	21	
MUSE- 4	21	
MUSE- 4T	21	
MUSE- 5	21	
MUSE- 5T	21	
MUSE- 6	21	
MUSE- 6T	21	
MUSE- 7	21	
MUSE- 7T	21	
MUSE- 8	21	
MUSE- 8T	21	
MUSE- 9	21	
MUSE- 9T	21	
MUSE-10	21	
MUSE-10T	21	
MUSE-11	21	
MUSE-11T	21	
MUSE-12	21	
MUSE-12T	21	

REF.	PAG.	PAG.
------	------	------

## N

NEC-1T	19	
NEC-2T	19	
NEC-3T	19	
NEF-1F 1	42	
NEF-1F 2	42	
NEF-1F 3	42	
NEF-1F 4	42	
NEF-1F 5	42	
NEF-1F 6	42	
NEF-1F 7	42	
NEF-1F 8	42	
NEF-1F 9	42	
NEF-1F10	42	
NEF-2Z 1	42	
NEF-2Z 2	42	
NEF-2Z 3	42	
NEF-2Z 4	42	
NEF-2Z 5	42	
NEF-2Z 6	42	
NEF-2Z 7	42	
NEF-2Z 8	42	
NEF-2Z 9	42	
NEF-2Z10	42	
NUG-1	58	

## P

PDL-3	19	
PDL-4	19	
PDL-5	19	
PDL-6	19	
PDL-7	19	
PDL-8	19	
PDL-9	19	
PDL-10	19	
PDL-11	19	
PDL-12	19	
PDL-13	19	
PDL-14	19	
PIC-1E	4	
PIC-1F 1	22	
PIC-1F 2	22	
PIC-1F 3	22	
PIC-1F 4	22	
PIC-1F 5	22	
PIC-1F 6	22	
PIC-1F 7	22	
PIC-1F 8	22	
PIC-1F 9	22	
PIC-1F10	22	
PIC-1F11	22	
PIC-1F12	22	
PIC-1F17	22	
PIC-1F18	22	
PIC-1F19	22	

REF.	PAG.	PAG.
------	------	------

PIC-1F20	22	
PIC-1F21	22	
PIC-1F22	22	
PIC-1F23	22	
PIC-1F24	22	
PIC-1F27	22	
PIC-1F28	22	
PIC-1F29	22	
PIC-1F30	22	
PIC-1F37	22	
PIC-1F38	22	
PIC-1F43	22	
PIC-1F44	22	
PIC-1F49	22	
PIC-1F50	22	
PIC-1F57	22	
PIC-1F58	22	
PIC-1F61	22	
PIC-1F62	22	
PIC-1F63	22	
PIC-1F64	22	
PIC-1F75	22	
PIC-1F76	22	
PIC-1F85	22	
PIC-1F86	22	
PIC-3E	4	
PIC-4E	4	
PIC-105F 1	23-24	
PIC-105F 2	23-24	
PIC-105F 3	23-24	
PIC-105F 4	23-24	
PIC-105F 5	23-24	
PIC-105F 6	23-24	
PIC-105F 7	23-24	
PIC-105F 8	23-24	
PIC-105F 9	23-24	
PIC-105F10	23-24	
PIC-105F11	23-24	
PIC-105F12	23-24	
PIC-105F13	23-24	
PIC-105F14	23-24	
PIC-105F15	23-24	
PIC-105F16	23-24	
PIC-105F17	23-24	
PIC-105F18	23-24	
PIC-105F19	23-24	
PIC-105F20	23-24	
PIC-105F21	23-24	
PIC-105F22	23-24	
PIC-105F23	23-24	
PIC-105F24	23-24	
PIC-105F25	23-24	
PIC-105F26	23-24	
PIC-105F27	23-24	
PIC-105F28	23-24	
PIC-105F29	23-24	
PIC-105F30	23-24	
PIC-105F31	23-24	

REF.	PAG.	PAG.
------	------	------

PIC-105F32	23-24	
PIC-105F33	23-24	
PIC-105F34	23-24	
PIC-105F35	23-24	
PIC-105F36	23-24	
PIC-105F37	23-24	
PIC-105F38	23-24	
PIC-105F39	23-24	
PIC-105F40	23-24	
PIC-105F41	23-24	
PIC-105F42	23-24	
PIC-105F43	23-24	
PIC-105F44	23-24	
PIC-105F45	23-24	
PIC-105F46	23-24	
PIC-105F47	23-24	
PIC-105F48	23-24	
PIC-105F49	23-24	
PIC-105F50	23-24	
PIC-105F51	23-24	
PIC-105F53	23-24	
PIC-105F54	23-24	
PIC-105F55	23-24	
PIC-105F56	23-24	
PIC-105F57	23-24	
PIC-105F58	23-24	
PIC-105F59	23-24	
PIC-105F60	23-24	
PIC-105F61	23-24	
PIC-105F62	23-24	
PIC-105F63	23-24	
PIC-105F64	23-24	
PIC-105F65	23-24	
PIC-105F66	23-24	
PIC-105F67	23-24	
PIC-105F68	23-24	
PIC-105F69	23-24	
PIC-105F70	23-24	
PIC-105F71	23-24	
PIC-105F72	23-24	
PIC-105F73	23-24	
PIC-105F74	23-24	
PIC-105F75	23-24	
PIC-105F76	23-24	
PIC-105F77	23-24	
PIC-105F78	23-24	
PIC-105F79	23-24	
PIC-105F80	23-24	
PIC-105F81	23-24	
PIC-105F82	23-24	
PIC-105F83	23-24	
PIC-105F84	23-24	
PIC-105F85	23-24	
PIC-105F86	23-24	
PIC-105F87	23-24	
PIC-105F88	23-24	
PIC-105F89	23-24	
PIC-105F90	23-24	

REF.	PAG.	PAG.
------	------	------

PIC-105F91	23-24	
PIC-105F92	23-24	
PIC-105L 1	10	
PIC-105L 2	10	
PIC-105L 3	10	
PIC-105L 4	10	
PIC-105L 5	10	
PIC-105L 6	10	
PIC-105L 7	10	
PIC-105L 8	10	
PIC-105L 9	10	
PIC-105L10	10	
PIC-105L11	10	
PIC-105L12	10	
PIC-105L13	10	
PIC-105L14	10	
PIC-105L15	10	
PIC-105L16	10	
PIC-105L17	10	
PIC-105L18	10	
PIC-105L19	10	
PIC-105L20	10	
PIC-105L21	10	
PIC-105L22	10	
PIC-105L23	10	
PIC-105L24	10	
PIC-105L25	10	
PIC-105L26	10	
PIC-105L27	10	
PIC-105L28	10	
PIC-105L29	10	
PIC-105L30	10	
PIC-110F 1	23-24	
PIC-110F 2	23-24	
PIC-110F 3	23-24	
PIC-110F 4	23-24	
PIC-110F 5	23-24	
PIC-110F 6	23-24	
PIC-110F 7	23-24	
PIC-110F 8	23-24	
PIC-110F 9	23-24	
PIC-110F10	23-24	
PIC-110F11	23-24	
PIC-110F12	23-24	
PIC-110F13	23-24	
PIC-110F14	23-24	
PIC-110F15	23-24	
PIC-110F16	23-24	
PIC-110F17	23-24	
PIC-110F18	23-24	
PIC-110F19	23-24	
PIC-110F20	23-24	
PIC-110F21	23-24	
PIC-110F22	23-24	
PIC-110F23	23-24	
PIC-110F24	23-24	
PIC-110F25	23-24	
PIC-110F26	23-24	



REF.	PAG.	PAG.
PIC-130F84	23-24	
PIC-130F85	23-24	
PIC-130F86	23-24	
PIC-130F87	23-24	
PIC-130F88	23-24	
PIC-130F89	23-24	
PIC-130F90	23-24	
PIC-130F91	23-24	
PIC-130F92	23-24	
PIC-140F 1	23-24	
PIC-140F 2	23-24	
PIC-140F 3	23-24	
PIC-140F 4	23-24	
PIC-140F 5	23-24	
PIC-140F 6	23-24	
PIC-140F 7	23-24	
PIC-140F 8	23-24	
PIC-140F 9	23-24	
PIC-140F10	23-24	
PIC-140F11	23-24	
PIC-140F12	23-24	
PIC-140F13	23-24	
PIC-140F14	23-24	
PIC-140F15	23-24	
PIC-140F16	23-24	
PIC-140F17	23-24	
PIC-140F18	23-24	
PIC-140F19	23-24	
PIC-140F20	23-24	
PIC-140F21	23-24	
PIC-140F22	23-24	
PIC-140F23	23-24	
PIC-140F24	23-24	
PIC-140F25	23-24	
PIC-140F26	23-24	
PIC-140F27	23-24	
PIC-140F28	23-24	
PIC-140F29	23-24	
PIC-140F30	23-24	
PIC-140F31	23-24	
PIC-140F32	23-24	
PIC-140F33	23-24	
PIC-140F34	23-24	
PIC-140F35	23-24	
PIC-140F36	23-24	
PIC-140F37	23-24	
PIC-140F38	23-24	
PIC-140F39	23-24	
PIC-140F40	23-24	
PIC-140F41	23-24	
PIC-140F42	23-24	
PIC-140F43	23-24	
PIC-140F44	23-24	
PIC-140F45	23-24	
PIC-140F46	23-24	
PIC-140F49	23-24	
PIC-140F50	23-24	

REF.	PAG.	PAG.
PIC-140F51	23-24	
PIC-140F53	23-24	
PIC-140F54	23-24	
PIC-140F55	23-24	
PIC-140F56	23-24	
PIC-140F57	23-24	
PIC-140F58	23-24	
PIC-140F59	23-24	
PIC-140F60	23-24	
PIC-140F61	23-24	
PIC-140F62	23-24	
PIC-140F63	23-24	
PIC-140F64	23-24	
PIC-140F65	23-24	
PIC-140F66	23-24	
PIC-140F67	23-24	
PIC-140F68	23-24	
PIC-140F69	23-24	
PIC-140F70	23-24	
PIC-140F71	23-24	
PIC-140F72	23-24	
PIC-140F73	23-24	
PIC-140F74	23-24	
PIC-140F75	23-24	
PIC-140F76	23-24	
PIC-140F77	23-24	
PIC-140F78	23-24	
PIC-140F79	23-24	
PIC-140F80	23-24	
PIC-140F81	23-24	
PIC-140F82	23-24	
PIC-140F83	23-24	
PIC-140F84	23-24	
PIC-140F85	23-24	
PIC-140F86	23-24	
PIC-140F87	23-24	
PIC-140F88	23-24	
PIC-140F89	23-24	
PIC-140F90	23-24	
PIC-140F91	23-24	
PIC-140F92	23-24	
PLE-3	22	
PLE-3T	22	
PLE-4	22	
PLE-4T	22	
PLE-5	22	
PLE-5T	22	
PLE-6	22	
PLE-6T	22	
PLE-7	22	
PLE-7T	22	
PLE-8	22	
PLE-8T	22	
PLE-9	22	
PLE-9T	22	
PLE-10	22	
PLE-10T	22	

REF.	PAG.	PAG.
PLE-11	22	
PLE-11T	22	
PLE-12	22	
PLE-12T	22	
POL-3TEC	3	
POL-5TEC	3	
PRT-1	20	
PRT-2	20	
PRT-3	20	
PRT-4	20	
PRT-5	20	

## R

RAD-4F	20	
RAD-5F	20	
RAD-6F	20	
RIL-1	53	
RO-1X	41	
RO-35P	61	
RUB-1	43	
RUB-7	43	

## S

SE-1X	43	
SEL-1	43	
SEL-3L	43	
SES-1Z 1	44	
SES-1Z 2	44	
SES-1Z 3	44	
SES-1Z 4	44	
SES-1Z 5	44	
SES-1Z 6	44	
SES-1Z 9	44	
SES-1Z10	44	
SES-1Z11	44	
SES-1Z12	44	
SES-1Z13	44	
SES-1Z14	44	
SES-2Z 1	44	
SES-2Z 2	44	
SES-2Z 3	44	
SES-2Z 4	44	
SES-2Z 5	44	
SES-2Z 6	44	
SES-2Z 7	44	
SES-2Z 8	44	
SES-2Z 9	44	
SES-2Z10	44	
SES-2Z11	44	
SES-2Z12	44	
SES-2Z13	44	
SES-2Z14	44	
SES-2Z15	44	
SES-2Z16	44	
SES-3Z 1	44	

REF.	PAG.	PAG.
SES-3Z 2	44	
SES-3Z 3	44	
SES-3Z 4	44	
SES-3Z 5	44	
SES-3Z 6	44	
SES-3Z 9	44	
SES-3Z10	44	
SES-3Z11	44	
SES-3Z12	44	
SES-3Z13	44	
SES-3Z14	44	
STML-1F 1	45	
STML-1F 2	45	
STML-1F 3	45	
STML-1F 4	45	
STML-1F 7	45	
STML-1F 8	45	
STML-1F 9	45	
STML-1F10	45	
STML-1F11	45	
STML-1F12	45	
STML-1F19	45	
STML-1F20	45	
STML-1F23	45	
STML-1F24	45	
STML-1F25	45	
STML-1F26	45	
STML-2F 1	45	
STML-2F 2	45	
STML-2F 3	45	
STML-2F 4	45	
STML-2F 7	45	
STML-2F 8	45	
STML-2F 9	45	
STML-2F10	45	
STML-2F11	45	
STML-2F12	45	
STML-2F15	45	
STML-2F16	45	
STML-2F17	45	
STML-2F18	45	
STML-2F19	45	
STML-2F20	45	
STML-3F 5	45	
STML-3F 6	45	
STML-3F27	45	
STML-3F28	45	
STML-3F29	45	
STML-3F30	45	
STML-4F 1	45	
STML-4F 2	45	
STML-4F 3	45	
STML-4F 4	45	
STML-4F 5	45	
STML-4F 6	45	
STML-4F 7	45	
STML-4F 8	45	

# INDEX GENERAL

REF.	PAG.	PAG.
STML-4F 9	45	
STML-4F10	45	
STML-4F11	45	
STML-4F12	45	
STML-4F13	45	
STML-4F14	45	
STS-T10A	61	
STS-T15	61	
STU-1	45	
SURE-1T	25	

## T

TE-8DKT	61	
TE-8DKT1	61	

## U

UN-105F 1	23-24	
UN-105F 2	23-24	
UN-105F 3	23-24	
UN-105F 4	23-24	
UN-105F 5	23-24	
UN-105F 6	23-24	
UN-105F 7	23-24	
UN-105F 8	23-24	
UN-105F 9	23-24	
UN-105F10	23-24	
UN-105F11	23-24	
UN-105F12	23-24	
UN-105F13	23-24	
UN-105F14	23-24	
UN-105F15	23-24	
UN-105F16	23-24	
UN-105F17	23-24	
UN-105F18	23-24	
UN-105F19	23-24	
UN-105F20	23-24	
UN-105F21	23-24	
UN-105F22	23-24	
UN-105F23	23-24	
UN-105F24	23-24	
UN-105F25	23-24	
UN-105F26	23-24	
UN-105F27	23-24	
UN-105F28	23-24	
UN-105F29	23-24	
UN-105F30	23-24	
UN-105F31	23-24	
UN-105F32	23-24	
UN-105F33	23-24	
UN-105F34	23-24	
UN-105F35	23-24	
UN-105F36	23-24	
UN-105F37	23-24	
UN-105F38	23-24	
UN-105F39	23-24	

REF.	PAG.	PAG.
UN-105F40	23-24	
UN-105F41	23-24	
UN-105F42	23-24	
UN-105F43	23-24	
UN-105F44	23-24	
UN-105F45	23-24	
UN-105F46	23-24	
UN-105F47	23-24	
UN-105F48	23-24	
UN-105F49	23-24	
UN-105F50	23-24	
UN-105F51	23-24	
UN-105F53	23-24	
UN-105F54	23-24	
UN-105F55	23-24	
UN-105F56	23-24	
UN-105F57	23-24	
UN-105F58	23-24	
UN-105F59	23-24	
UN-105F60	23-24	
UN-105F61	23-24	
UN-105F62	23-24	
UN-105F63	23-24	
UN-105F64	23-24	
UN-105F65	23-24	
UN-105F66	23-24	
UN-105F67	23-24	
UN-105F68	23-24	
UN-105F69	23-24	
UN-105F70	23-24	
UN-105F71	23-24	
UN-105F72	23-24	
UN-105F73	23-24	
UN-105F74	23-24	
UN-105F75	23-24	
UN-105F76	23-24	
UN-105F77	23-24	
UN-105F78	23-24	
UN-105F79	23-24	
UN-105F80	23-24	
UN-105F81	23-24	
UN-105F82	23-24	
UN-105F83	23-24	
UN-105F84	23-24	
UN-105F85	23-24	
UN-105F86	23-24	
UN-105F87	23-24	
UN-105F88	23-24	
UN-105F89	23-24	
UN-105F90	23-24	
UN-105F91	23-24	
UN-105F92	23-24	
UN-105FT 1	23-24	
UN-105FT 2	23-24	
UN-105FT 3	23-24	
UN-105FT 4	23-24	
UN-105FT 5	23-24	

REF.	PAG.	PAG.
UN-105FT 6	23-24	
UN-105FT 7	23-24	
UN-105FT 8	23-24	
UN-105FT 9	23-24	
UN-105FT10	23-24	
UN-105FT11	23-24	
UN-105FT12	23-24	
UN-105FT13	23-24	
UN-105FT14	23-24	
UN-105FT15	23-24	
UN-105FT16	23-24	
UN-105FT17	23-24	
UN-105FT18	23-24	
UN-105FT19	23-24	
UN-105FT20	23-24	
UN-105FT21	23-24	
UN-105FT22	23-24	
UN-105FT23	23-24	
UN-105FT24	23-24	
UN-105FT25	23-24	
UN-105FT26	23-24	
UN-105FT27	23-24	
UN-105FT28	23-24	
UN-105FT29	23-24	
UN-105FT30	23-24	
UN-105FT31	23-24	
UN-105FT32	23-24	

## V

V-3G	51	
V-3G(CV)	51	
V-4G(CV)	50	
V-5G(CV)	50	
VA- 1T	46	
VA- 2T	46	
VA- 3T	46	
VA- 5T	46	
VA- 9F 1	46	
VA- 9F 3	46	
VA- 9F11	46	
VA- 9F17	46	
VA- 9F21	46	
VA- 9F29	46	
VA- 15	53	
VA-400	46	
VA-700	46	
VERR-2T	25	
VERR-3T	25	
VITR-1T	20	

## Y

YA-30	53	
-------	----	--

# INDEX PAR MARQUES



**THE KEY TO EXCELLENCE**  
GLOBALLY UNLOCKING MILLIONS OF DOORS DAILY

## INDEX PAR MARQUES

REFERENCE	PAGE
-----------	------

### A

ADAPTABLE	7, 8, 9, 10, 13, 14, 22, 23, 24
ARMOIRE 1/2 TOUR	14
ARMOIRE ADAPTABLE	14
AVA-CHUBB	27

### B

BMH	42
BODE	27
BRICARD	27, 28

### C

CAVERS	1
CELINSA	61
CHUBB	27
CLES ADAPTABLES AVEC COLLERETTE	15
CLES CREMONE POUR BOUCHES DEAU	15
CLES CREMONES DE BATTEUSE EDF	16
CLES DE BUREAU	16
CLES DE CAVE	17
CLES DE CREMONE	18
CLES DE CREMONE A PANNETON	18
CLES DE MENOTTE	18
CLES DE MEUBLES ET COMMODE	19, 49, 50, 51
CLES DE NECESSAIRE	19
CLES DE PENDULE	19
CLES DE PLATES ACIER DIVERSES	53
CLES DE RADIATEURS	20
CLES DE VITRINE	20

### D

DEBEAURAIN-ND	28, 29, 30, 31, 39
DECAYEUX DAD	31
DENY	32
DU CERF	55

### E

EMERY	32
-------	----

### F

FH	42
FICHET	1, 32, 33, 55, 56, 57
FTH	1, 33, 34

### G

GOLLOT	34
GTV UNIVERSAL	35, 36

REFERENCE	PAGE
-----------	------

### J

JPM	1, 37, 38
-----	-----------

### K

KIMA	38
------	----

### L

LAPERCHE	1, 39, 45
LAURENT	40
LEGGÉ	15, 40
LITTO	15
LOQUETEAUX	20

### M

MAFOR	40, 41
MERMIER	41
MOREAUX	42
MORTICE	15
MUEL	42, 53
MUEL VAK	2, 3

### N

NEMEF	42
NUGUE	58

### P

PANNETON ANGLAIS	21
PANNETON MUSEAU	21
PANNETON PLEIN	22
PETIT-MALOIGNE	28
PICARDIE	10, 22, 23, 24
PICARDIE-UNION	23, 24
POLLUX	3
PROGRES	3
PROGRES-FONTAINE	3

### R

RIL	53
RONIS	41, 61
RUBIS	43

### S

SE	43
SELECT	43
SESA	44
SOS	41

# INDEX PAR MARQUES

REFERENCE	PAGE
<b>STREMLER</b>	39, 45
<b>STS</b>	61
<b>STUV</b>	45
<b>SURETE POUSSEE</b>	25
<b>T</b>	
<b>TESA</b>	61
<b>U</b>	
<b>UNION</b>	23, 24
<b>V</b>	
<b>VACHETTE</b>	38, 39, 42, 45, 46, 53
<b>VERROU</b>	25
<b>VIGIE PICARD</b>	4
<b>Y</b>	
<b>YALE</b>	53

***CLES A POMPE FRANÇAISES ET TYPE MUEL***



***THE KEY TO EXCELLENCE***  
GLOBALLY UNLOCKING MILLIONS OF DOORS DAILY











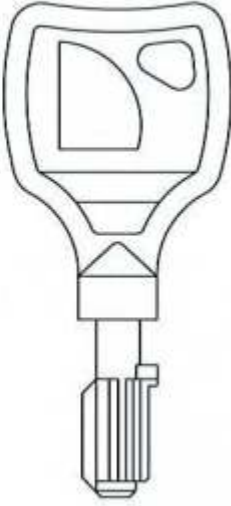



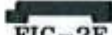

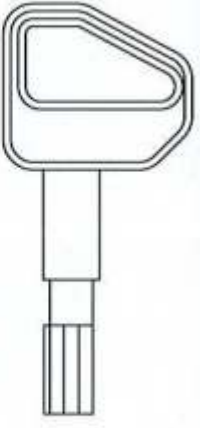
**POUR:**

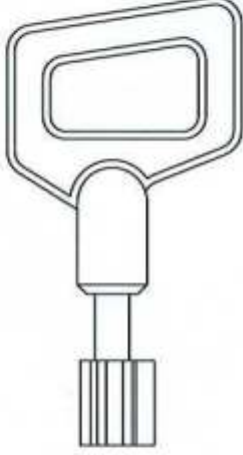
CAVERS (F)

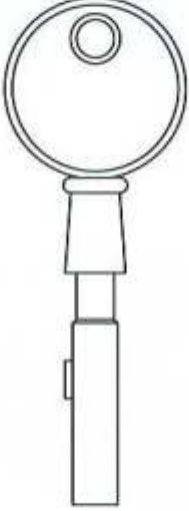
FICHET (F)

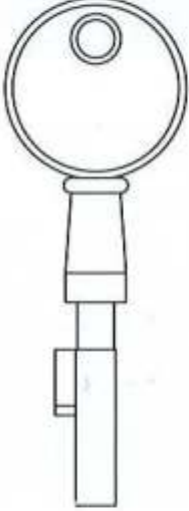
JPM (F)

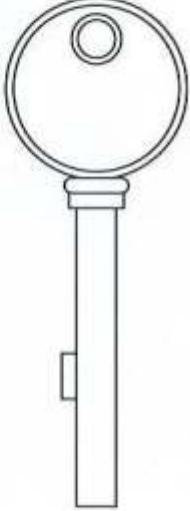
LAPERCHE (F)

CAVERS	FICHET			JPM
  <b>CA-1E</b> ORIGINALE-ZAMAK	  <b>FIC-1E</b>  <b>FIC-2E</b>  <b>FIC-3E</b> MAILLECHORT		  <b>JP-1EC</b> FTH-JPM 505 LAITON	
JPM	LAPERCHE			
  <b>JP-2EC</b> 405 LAITON	  UTILISER LAP-3E LAITON	  <b>LAP-2E</b> LAITON	  <b>LAP-3E</b> LAITON	

Copyright by  
Alejandro Altuna S.A.  
2011

**JMA**





1

# MUEL - VAK



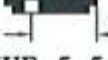
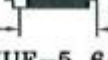

POUR:

MUEL VAK (F)



-  1.95
- MUE-5 1-7
-  3.55
- MUE-5 2-8
-  5.1
- MUE-5 3-9
-  7.1
- MUE-5 4-10
-  8.65
- MUE-5 5-11
-  10.25
- MUE-5 6-12



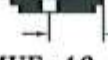
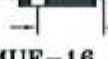
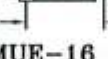

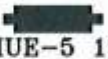

-  1.95
- MUE-16 0
-  1.95
- MUE-16 1
-  3.55
- MUE-16 2
-  5.1
- MUE-16 3
-  7.1
- MUE-16 4
-  8.65
- MUE-16 5
-  10.25
- MUE-16 6
- 6 GORGES

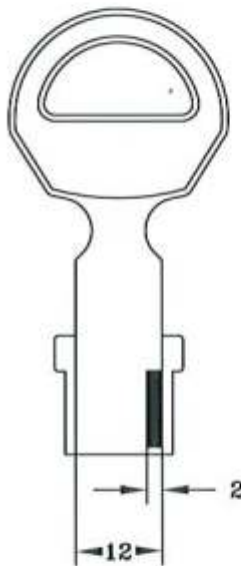

 13  
MUE-5 13

MAILLECHORT

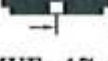
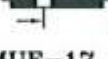
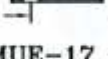
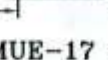

-  2
- MUE-17 0
-  3.75
- MUE-17 1
-  5.45
- MUE-17 2
-  7.1
- MUE-17 3
-  8.75
- MUE-17 4
-  10.45
- MUE-17 5
-  12.2
- MUE-17 6
-  12.2
- MUE-17 7
- 7 GORGES



-  6.4
- MUE-18 4
-  7.8
- MUE-18 5
- 8 GORGES

Copyright by  
Alejandro Altuna S.A.  
2011

**JMA**

POUR:

MUEL VAK (F)

POLLUX (F)

PROGRES  
FONTAINE  
(F)

### MUEL-VAK

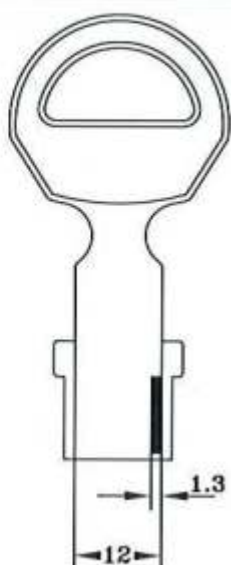

MUE-20 3



MUE-20 4



MUE-20 5



MUE-20 6



MUE-20 7



MUE-20 8



MUE-20 1



MUE-20 2



MUE-20 9



MUE-20 10

10 GORGES

### POLLUX

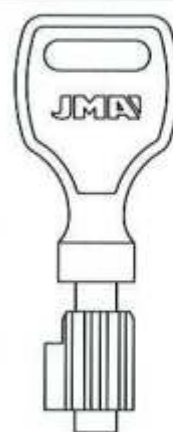

POL-3TEC



POL-5TEC

ZAMAK

### PROGRES-FONTAINE

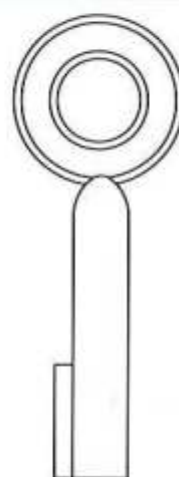
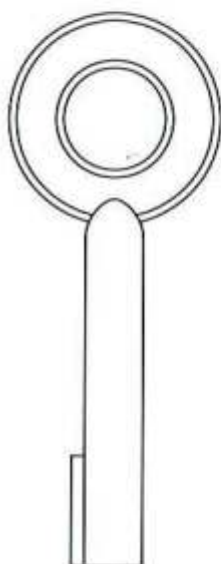

FON-1E



FON-2E



FON-3E



FON-6E



FON-4E



FON-5E

POUR FON-5E ET FON-6E UTILISER FON-3E  
LAITON

Copyright by  
Alejandro Altuna S.A.  
2011

**JMA**

3

VIGIE-PICARD

POUR:

VIGIE  
PICARD  
(F)

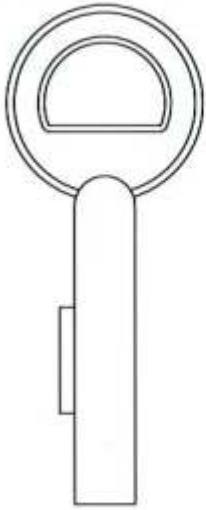

PIC-1E

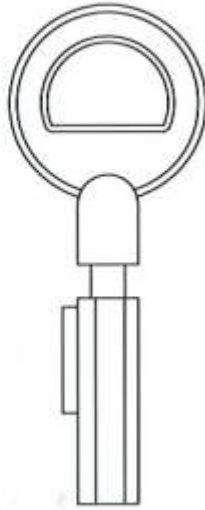

UTILISER PIC-3E

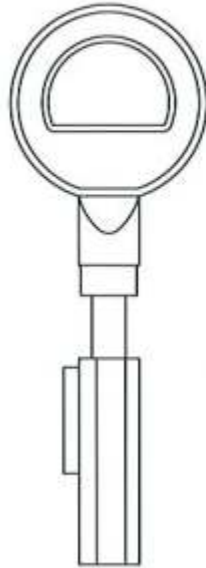

PIC-3E

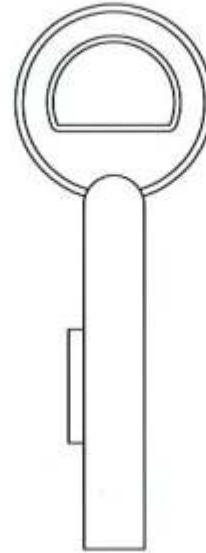

PIC-4E

LAITON

Copyright by  
Alejandro Altuna S.A.  
2011

**JMA**

***CLES ADAPTABLES A GORGES ET A CHIFFRES  
EN LAITON***

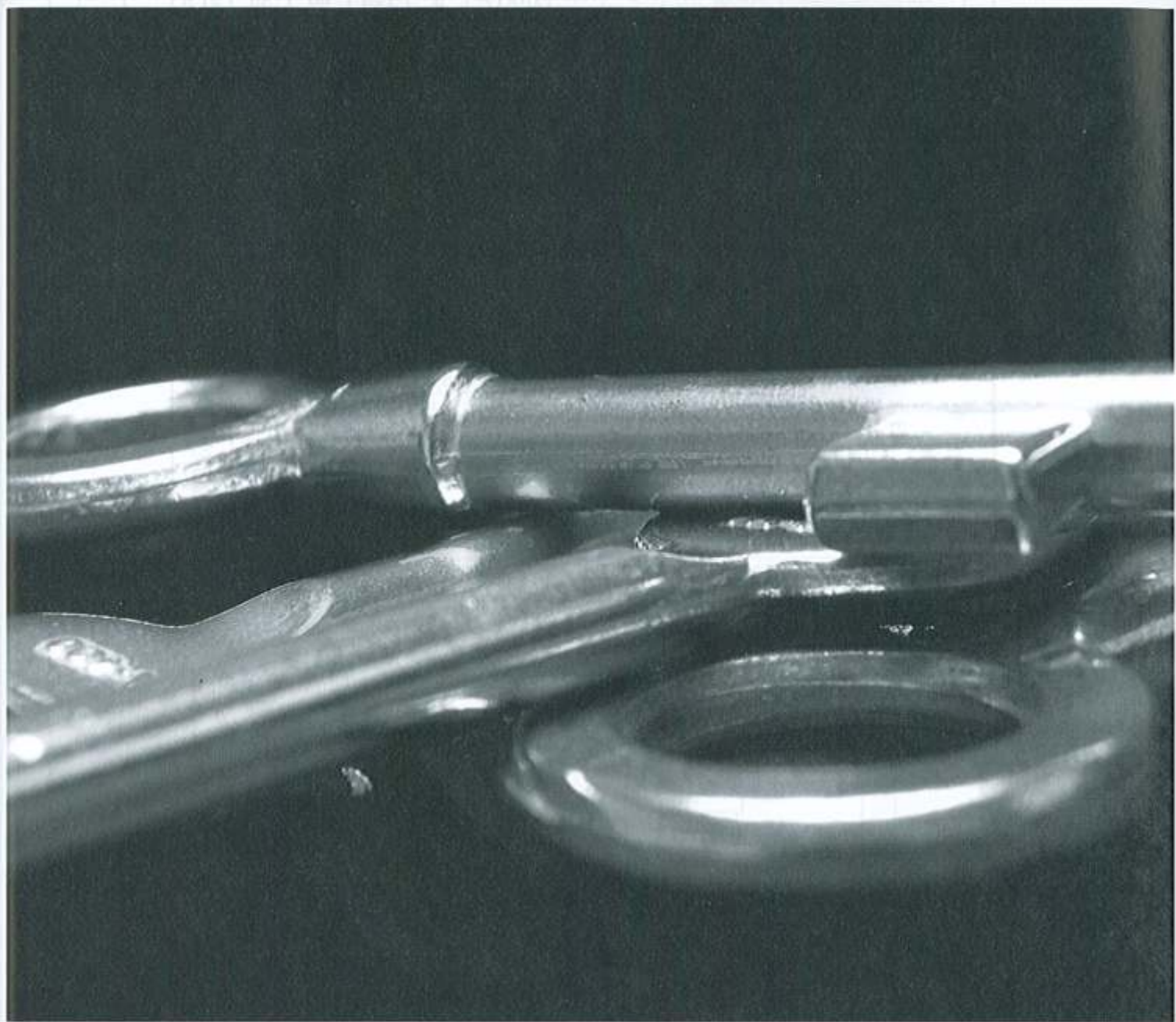

***THE KEY TO EXCELLENCE***  
GLOBALLY UNLOCKING MILLIONS OF DOORS DAILY

POUR:

## CLES A GORGES ADAPTABLES EN LAITON

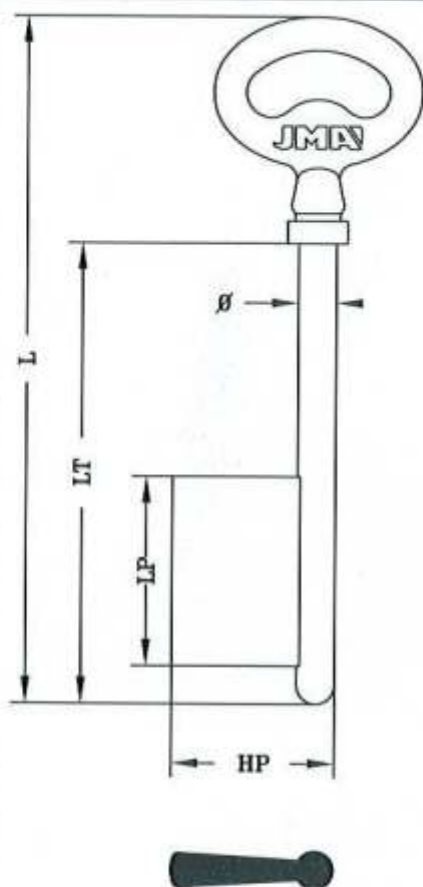

REF.	ø	L	LT	LP	HP
AD-3	5	90	60	25	21,5
AD-4	5	95	65	25	21,5
AD-5	5	100	70	25	21,5
AD-16	5	110	80	30	21,5
AD-17	5	120	89	35	21,5
AD-6	5,5	80	59	25	22
AD-7	5,5	95	64	25	22
AD-18	5,5	95	64	30	22
AD-8	5,5	100	70	25	21,5
AD-19	5,5	110	80	30	22
AD-20	5,5	120	89	35	22
AD-1	5,8	75	43	18	14
AD-9	5,8	80	50	25	19
AD-21	5,8	95	65	30	22
AD-10	6	90	59	25	22
AD-11	6	95	65	25	22
AD-12	6	100	70	25	22
AD-23	6	110	80	30	22
AD-24	6	120	88	35	22
AD-25	6	140	108	35	22
AD-26	6,5	95	65	30	23
AD-13	6,5	100	70	25	22
AD-29	6,5	100	70	30	23
AD-27	6,5	110	80	30	23
AD-28	6,5	120	90	35	23

## CLES A GORGES ADAPTABLES EN LAITON

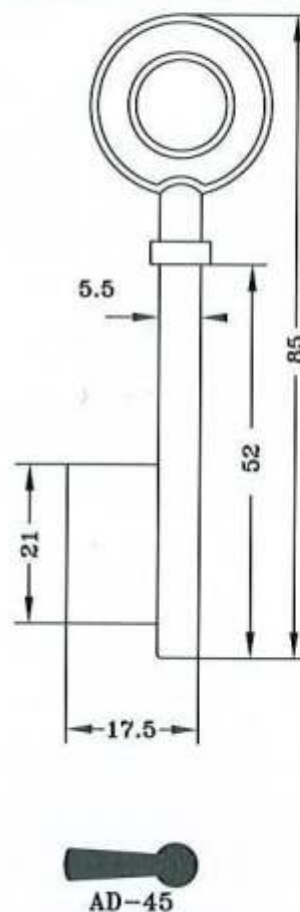
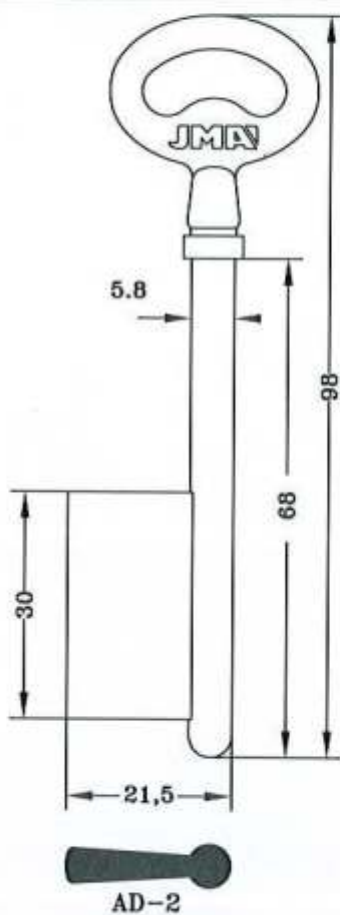

Copyright by  
Alejandro Altuna S.A.  
2011

**JMA**

7

# CLES A GORGES ADAPTABLES EN LAITON

POUR: \_\_\_\_\_

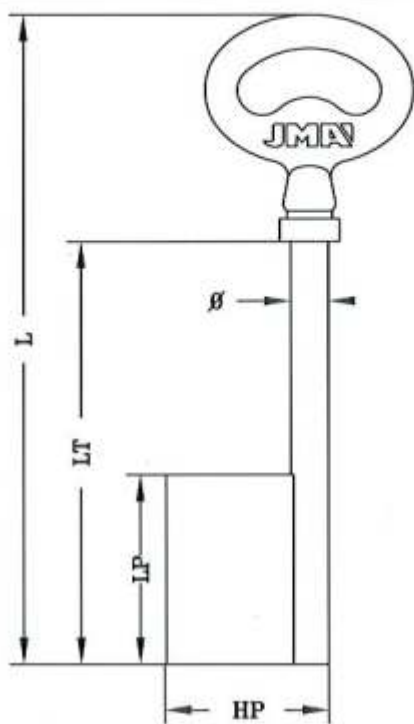

REF.	Ø	Ø INT	L	LT	LP	HP
AD-9T	5.8	4	75	43	25	22
AD-11T	5.8	4	90	59	25	22
AD-10T	6	4	85	54	25	22
AD-12T	6	4	95	64	25	22
AD-13T	6.5	4	95	63	35	22



## CLE DE MEUBLES FOREE AD. EN LAITON

## ADAPTABLES

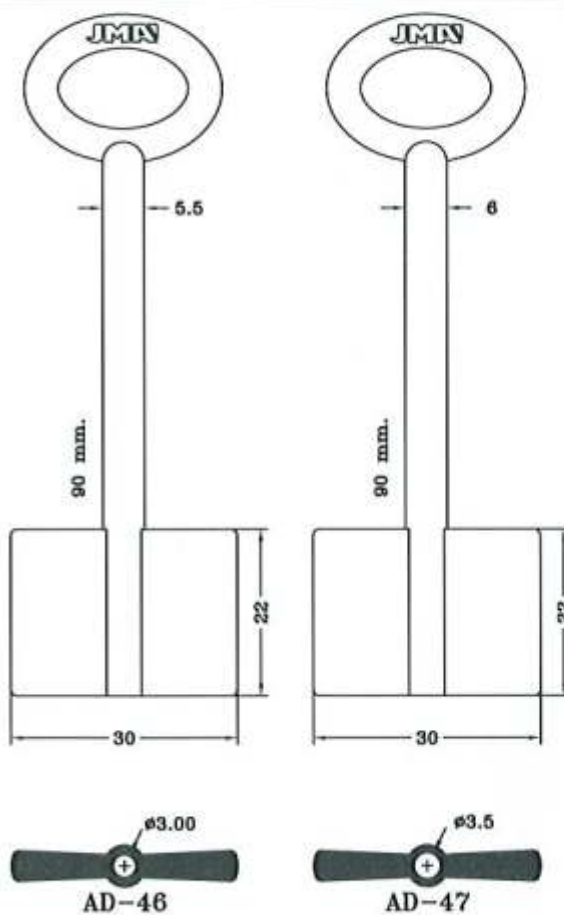
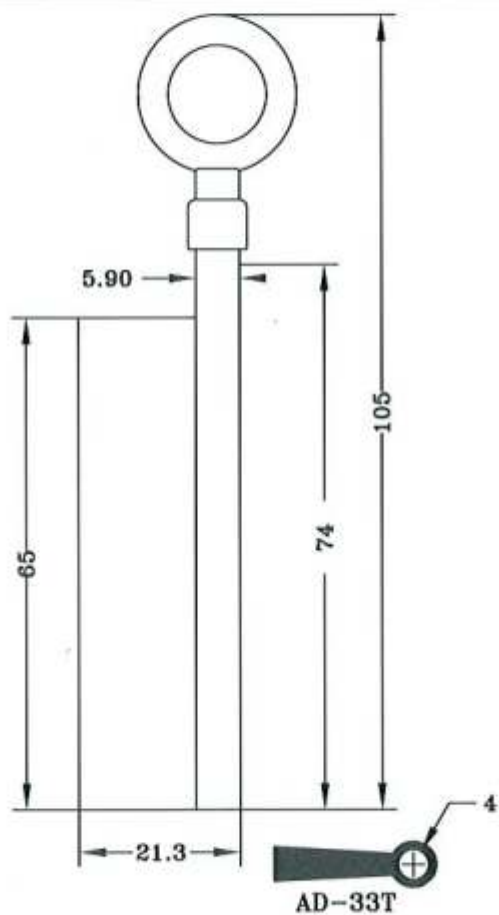

Copyright by  
Alejandro Altuna S.A.  
2011

**JMA**

POUR:

# CLES ADAPTABLES EN LAITON A PANNETON PLEIN



ADPLE-11

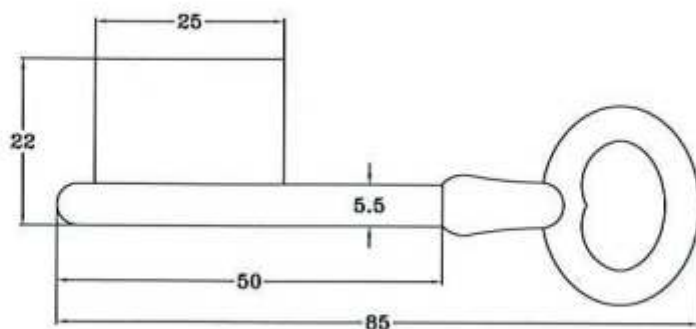

ADPLE-22

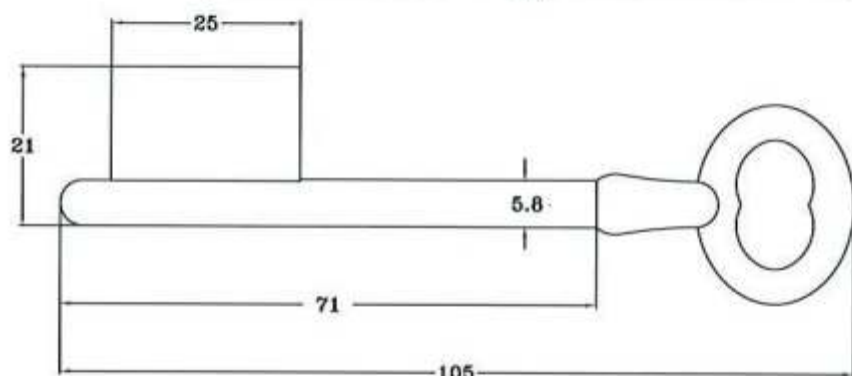

ADPLE-33

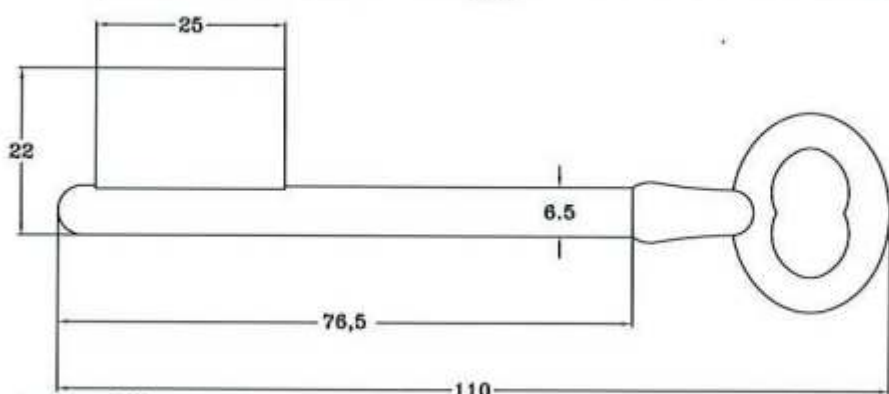

ADPLE-44

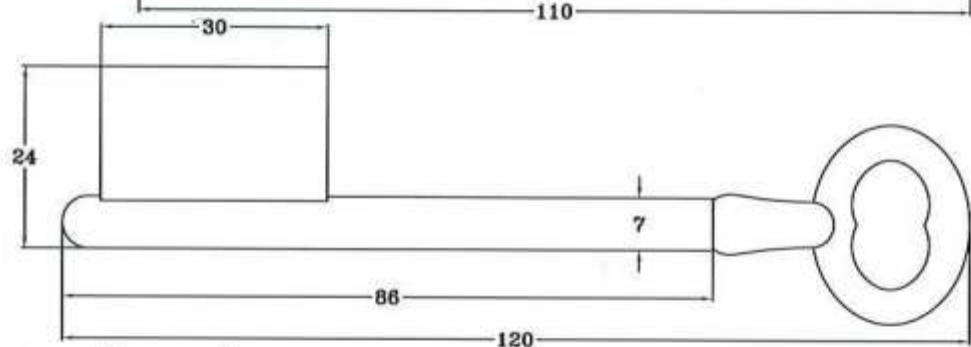

ADPLE-55

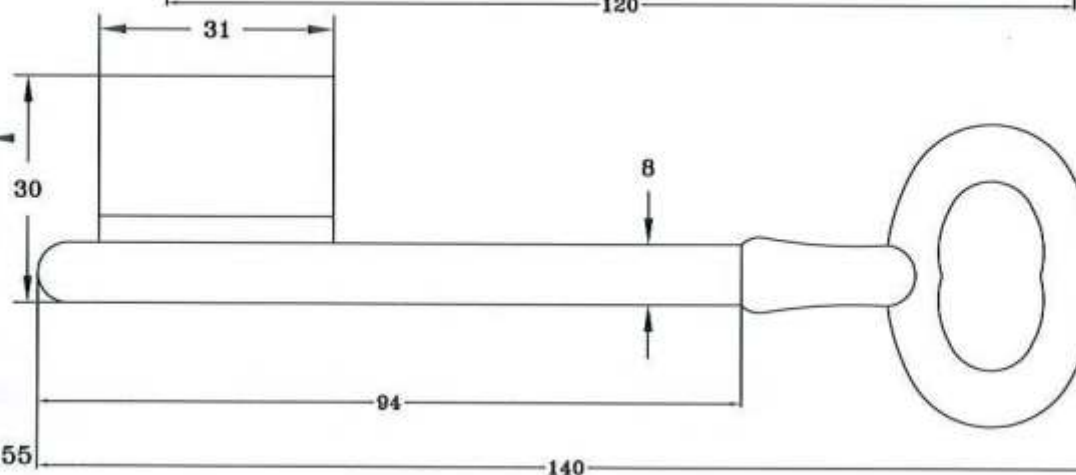

Copyright by  
Alejandro Altuna S.A.  
2011

**JMA**

9

CLES ADAPTABLES A CHIFFRES "PICARDIE" EN LAITON

POUR:

PICARDIE (F)

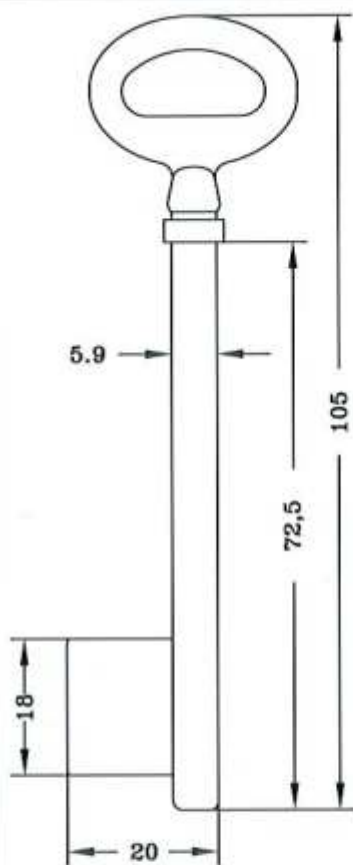

PIC-105L-...  
SUBSTITUTION ADPLE-22

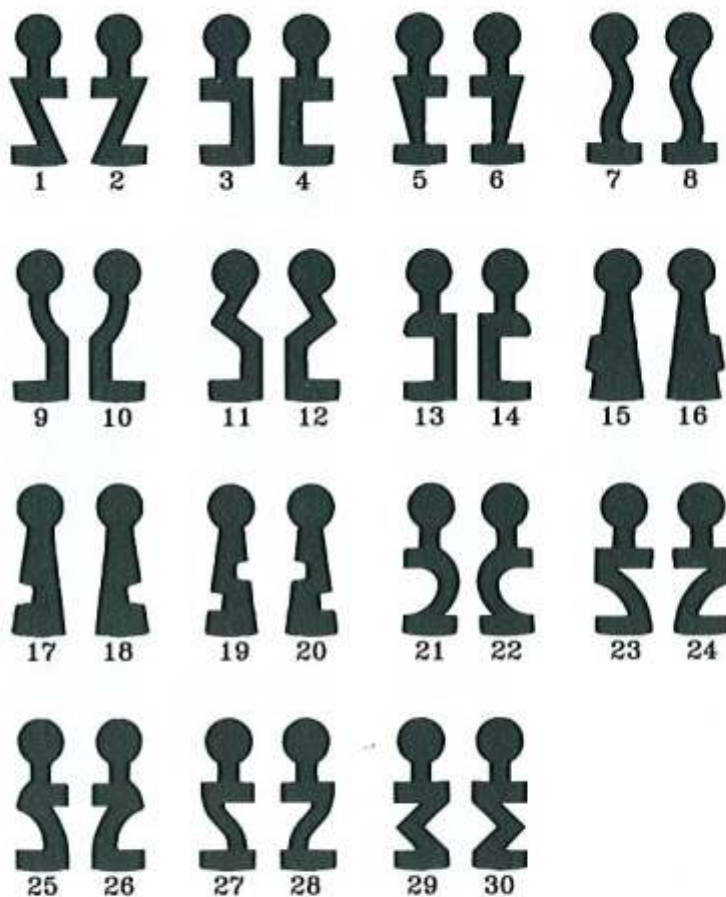

Copyright by  
Alejandro Altuna S.A.  
2011

**JMA**

***CLES ADAPTABLES A GORGES ET A CHIFFRES***  
***EN FONTE ET EN ACIER***



***THE KEY TO EXCELLENCE***  
*GLOBALLY UNLOCKING MILLIONS OF DOORS DAILY*

POUR:

# CLES A GORGES ADAPTABLES

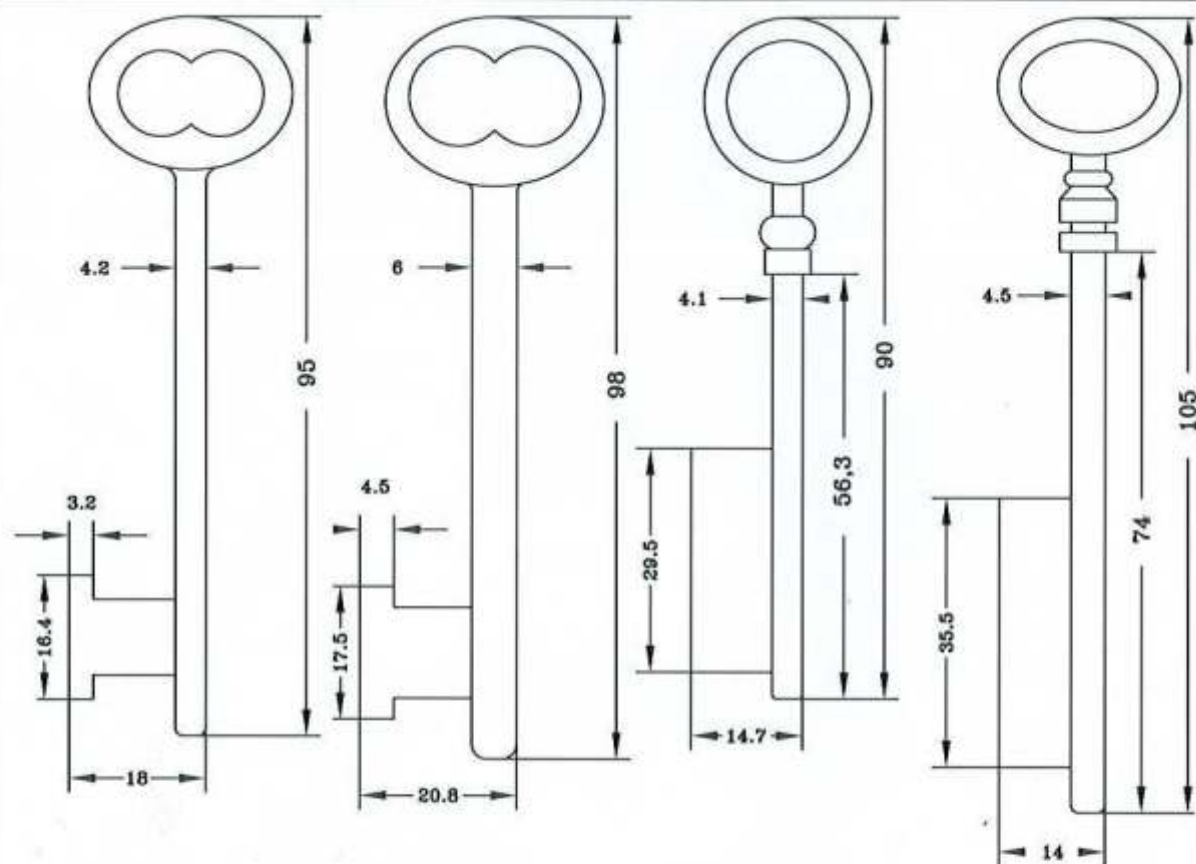

AD-1F

FONTE

AD-2F

FONTE

AD-3F

FONTE

AD-4F

FONTE

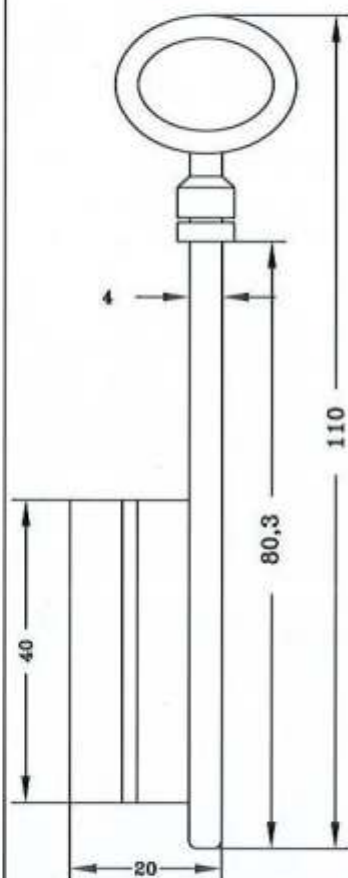

AD-5F

FONTE

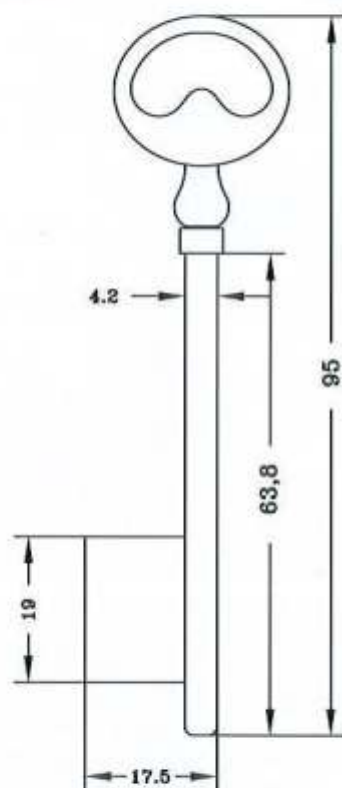

AD-6F-..

FONTE



1



2



3



4



5



6

Copyright by  
Alejandro Altuna S.A.  
2011

**JMA**

13

# CLES A GORGES ADAPTABLES

POUR: \_\_\_\_\_

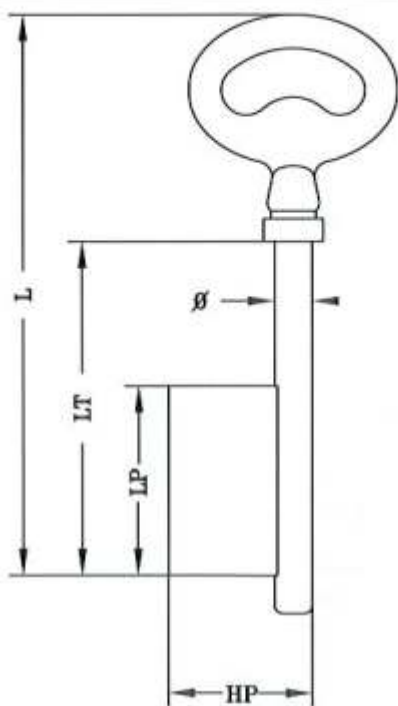

REF.	ø	L	LT	LP	HP
AD-38F	5	80	48	20	20
AD-7F	5	90	57	35	21
AD-9F	5	100	70	25	20,5
AD-11F	5	120	90	35	20,6
AD-13F	5	140	109	35	20,8
AD-40F	5,5	80	60	35	20,3
AD-14F	5,5	90	60	35	20,2
AD-16F	5,5	100	67	35	20,5
AD-18F	5,5	120	88	35	21
AD-20F	5,5	140	118	35	20
AD-41F	6	70	38	20	20,3
AD-42F	6	80	46	25	20,5
AD-21F	6	90	57	35	21
AD-23F	6	100	67	35	21,2
AD-25F	6	120	89	35	21,2
AD-27F	6	140	110	35	21,5
AD-43F	6,5	80	48	25	20
AD-28F	6,5	90	56	35	21,5
AD-29F	6,5	100	68	35	21,5
AD-31F	6,5	120	89	35	21,5
AD-33F	6,5	140	103	35	21
AD-34F	7	90	58	35	21
AD-35F	7	100	69	35	22,5
AD-36F	7	120	89	35	22,8
AD-37F	7	140	109	35	22,2



FONTE

## ARMOIRE 1/2 TOUR

## ARMOIRE ADAPTABLE

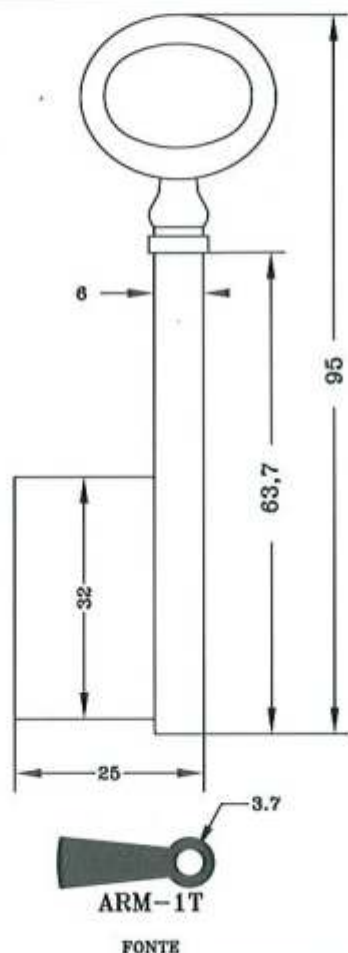

ARM-1T

FONTE

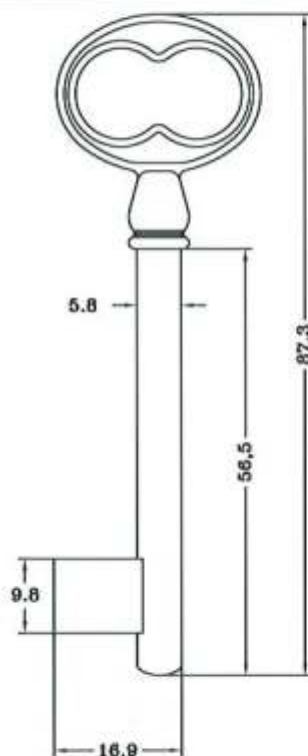

ARM-2F...  
SUBSTITUTION ADPLE-22  
FONTE



Copyright by  
Alejandro Altuna S.A.  
2011

**JMA**

14

POUR:

### CLES ADAPTABLES AVEC COLLERETTE

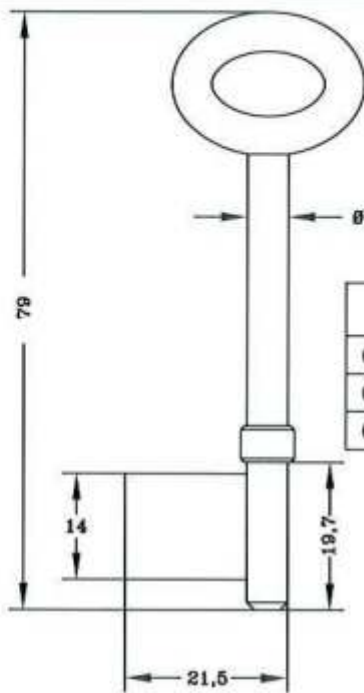

REF.	Ø
COLL-3	4.5
COLL-5	5
COLL-7	5.5

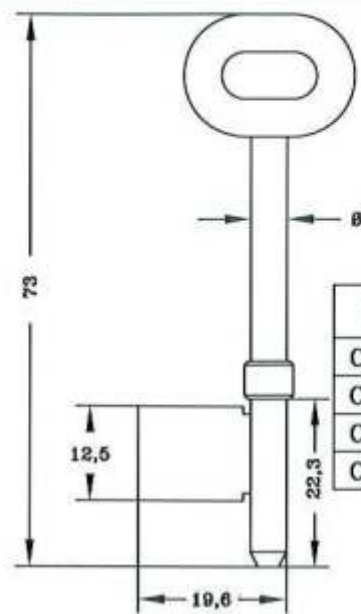

REF.	Ø
COLL-2	4
COLL-4	4.5
COLL-6	5
COLL-8	5.5



LITTO-LEGGE  
ACIER



LITTO-MORTICE  
ACIER

### CLES CREMONE POUR BOUCHES D'EAU

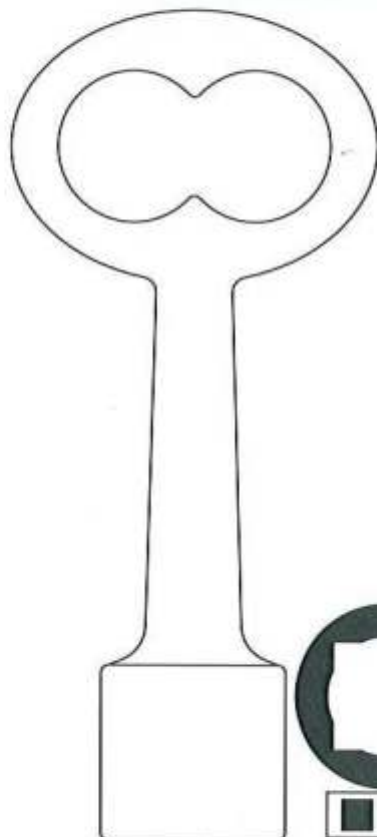

■	L
14	115

BEC-14F

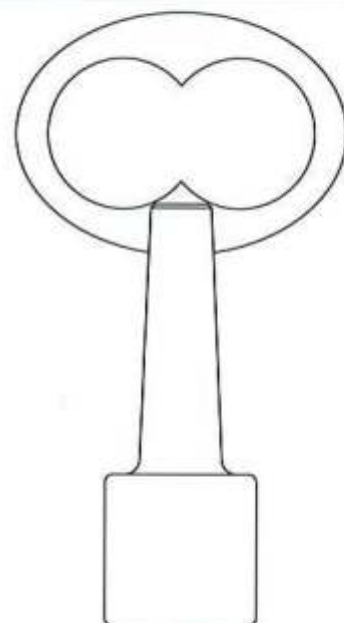

▲	L
14	115

BET-14F

FONTE

Copyright by  
Alejandro Altuna S.A.  
2011

**JMA**

**15**

CLE CREMONES DE BATTEUSE EDF

POUR: \_\_\_\_\_

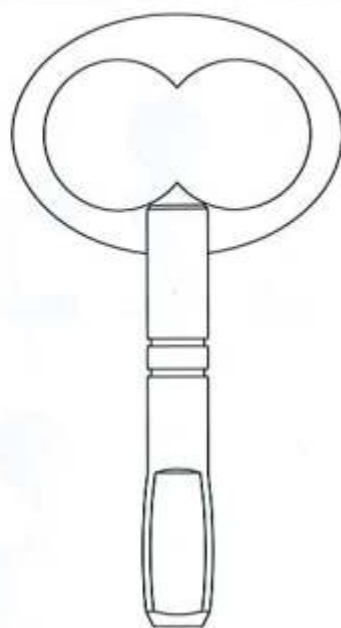

BED-1F

FONTE

CLE DE BUREAU

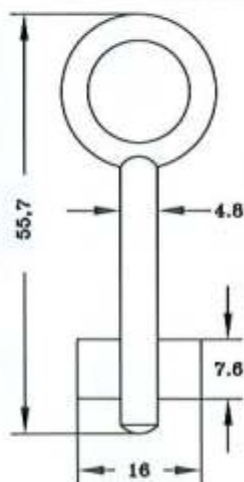

BAU-1

FONTE

Copyright by  
Alejandro Altuna S.A.  
2011

**JMA**

16

POUR:

# CLES DE CAVE

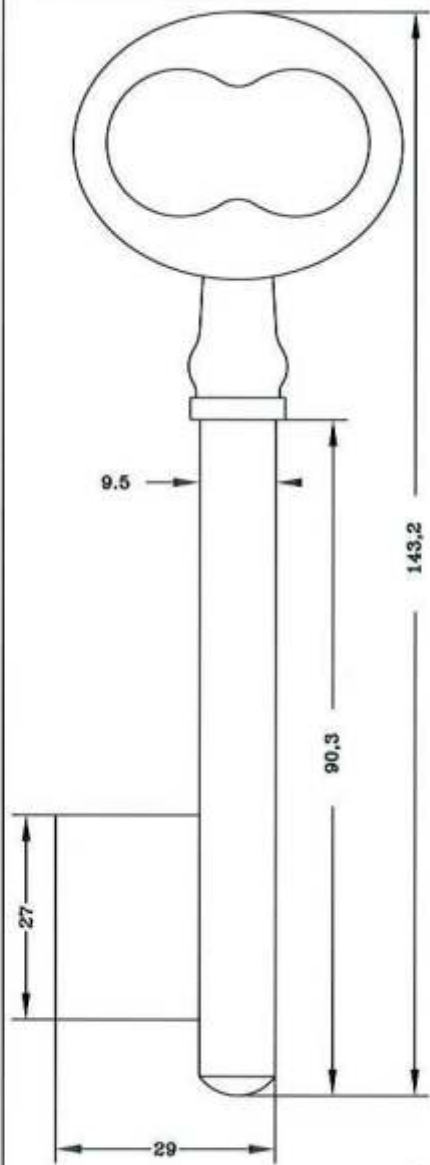

CAV-1F-..  
FONTE

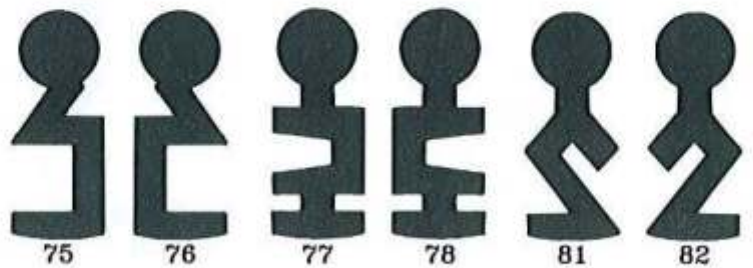
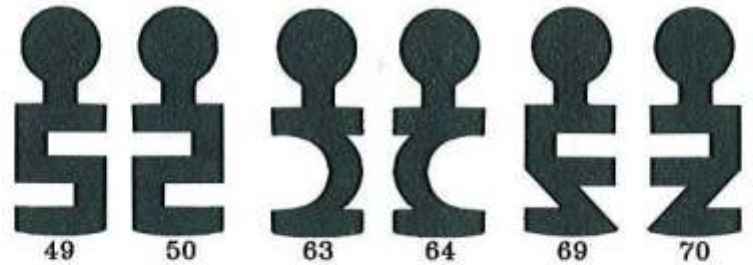

Copyright by  
Alejandro Altuna S.A.  
2011

**JMA**

CLES DE CREMONE

CLE CREMONE A PANNETON

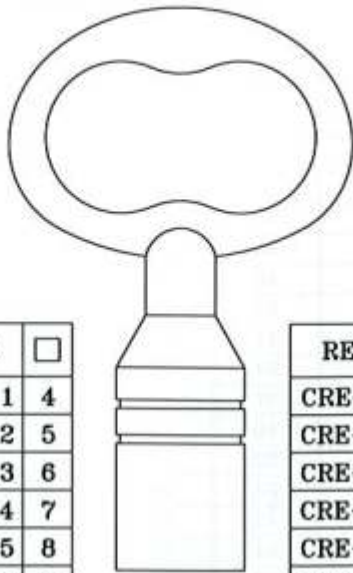

REF.	□
CRE-1	4
CRE-2	5
CRE-3	6
CRE-4	7
CRE-5	8
CRE-6	9
CRE-7	10
CRE-8	11
CRE-9	12

REF.	△
CRE-11	5
CRE-12	6
CRE-13	7
CRE-14	8
CRE-15	9
CRE-16	10
CRE-17	11
CRE-18	12

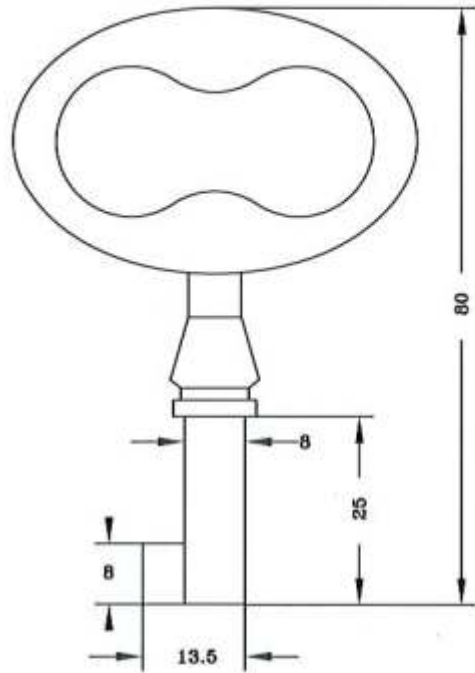

CLE CREMONE A PANNETON

CLES DE MENOTTE

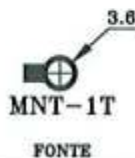
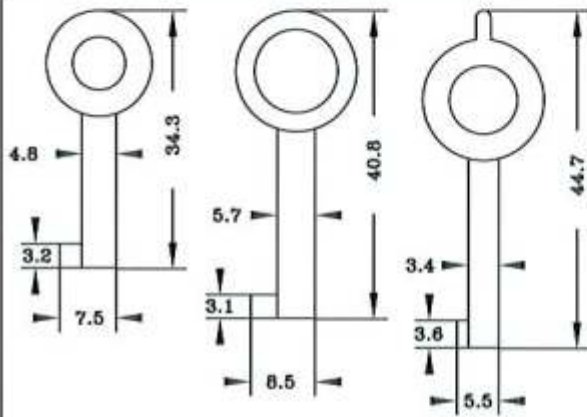
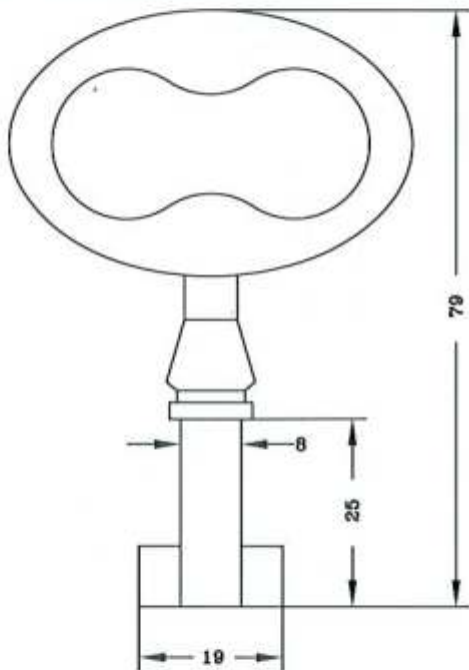

Copyright by  
Alejandro Altuna S.A.  
2011

**JMA**

POUR:

## CLES DE MEUBLES ET COMMODE

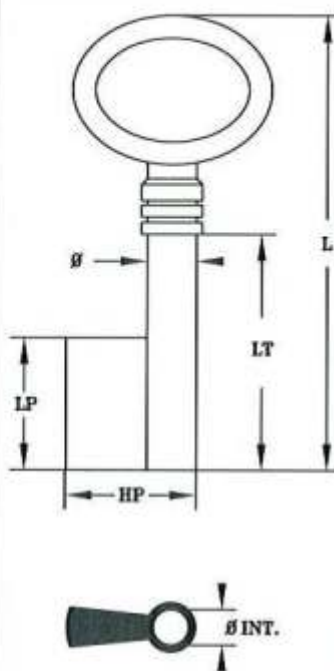

REF.	g	Ø INT.	L	LT	N.PANNE.	LP	HP
COM-1T	5	3	60	30	17	17	17,2
COM-2T	5	3	70	41	17	17,5	17,2
COM-3T	5	3	80	49	17	17,5	17,2
COM-4T	5,5	3,5	60	32	18	20	17,2
COM-5T	5,5	3,5	70	41	18	19,5	17,2
COM-6T	5,5	3,5	80	51	18	20	17,2
COM-7T	6	4	60	31	19	20	17,2
COM-8T	6	4	70	40	19	20	17,2
COM-9T	6	4	80	52	19	20	17,2
COM-10T	6,5	4,3	60	33	20	20	19
COM-11T	6,5	4,3	70	42	20	20	19
COM-12T	6,5	4,3	80	51	20	20	19
COM-13T	7	4,8	60	32	21	20	17,2
COM-14T	7	4,8	70	41	21	20	17,2
COM-15T	7	4,8	80	48	21	18	20
COM-16T	7,5	5,3	60	29	22	15	20
COM-17T	7,5	5,3	70	41	22	17,5	17,2
COM-18T	7,5	5,3	80	49	22	15	21

FONTE

## CLES DE NECESSAIRE

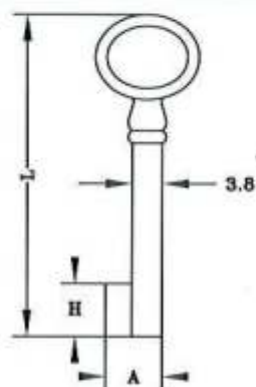

REF.	L	H	A
NEC-1T	25	4.3	7.1
NEC-2T	35	3.8	7.7
NEC-3T	40	6.4	8.6



FONTE

## CLES DE PENDULE

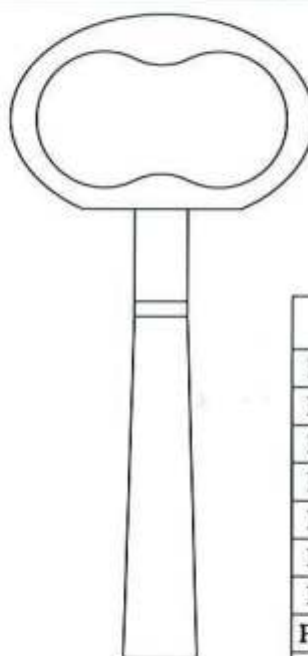

REF.	□
PDL-3	3.3
PDL-4	3.5
PDL-5	3.7
PDL-6	3.9
PDL-7	4.2
PDL-8	4.3
PDL-9	4.5
PDL-10	4.7
PDL-11	5
PDL-12	5.5
PDL-13	5.7
PDL-14	5.9



FONTE

Copyright by  
Alejandro Altuna S.A.  
2011

**JMA**

19

CLES DE RADIATEURS

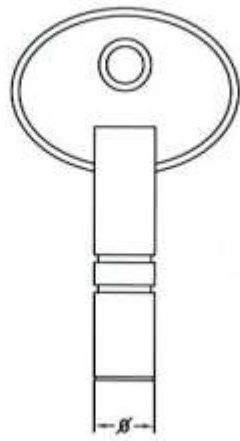

		Ø
RAD-4F	4	8
RAD-5F	5	10
RAD-6F	6	11

FONTE

CLES DE VITRINE

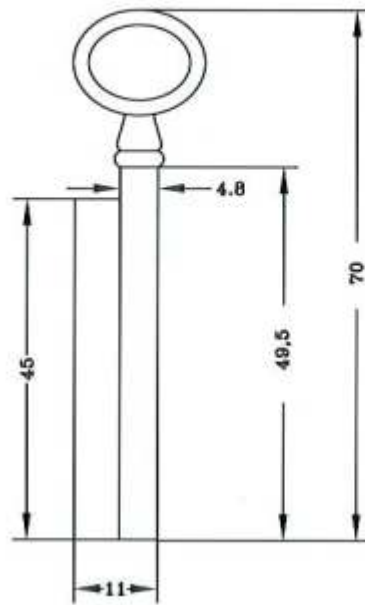

FONTE

POUR: \_\_\_\_\_

LOQUETEAUX



REF.	
PRT-1	4
PRT-2	5
PRT-3	6
PRT-4	7
PRT-5	8



FONTE

Copyright by  
Alejandro Altuna S.A.  
2011

**JMA**

POUR:

## PANNETON ANGLAIS

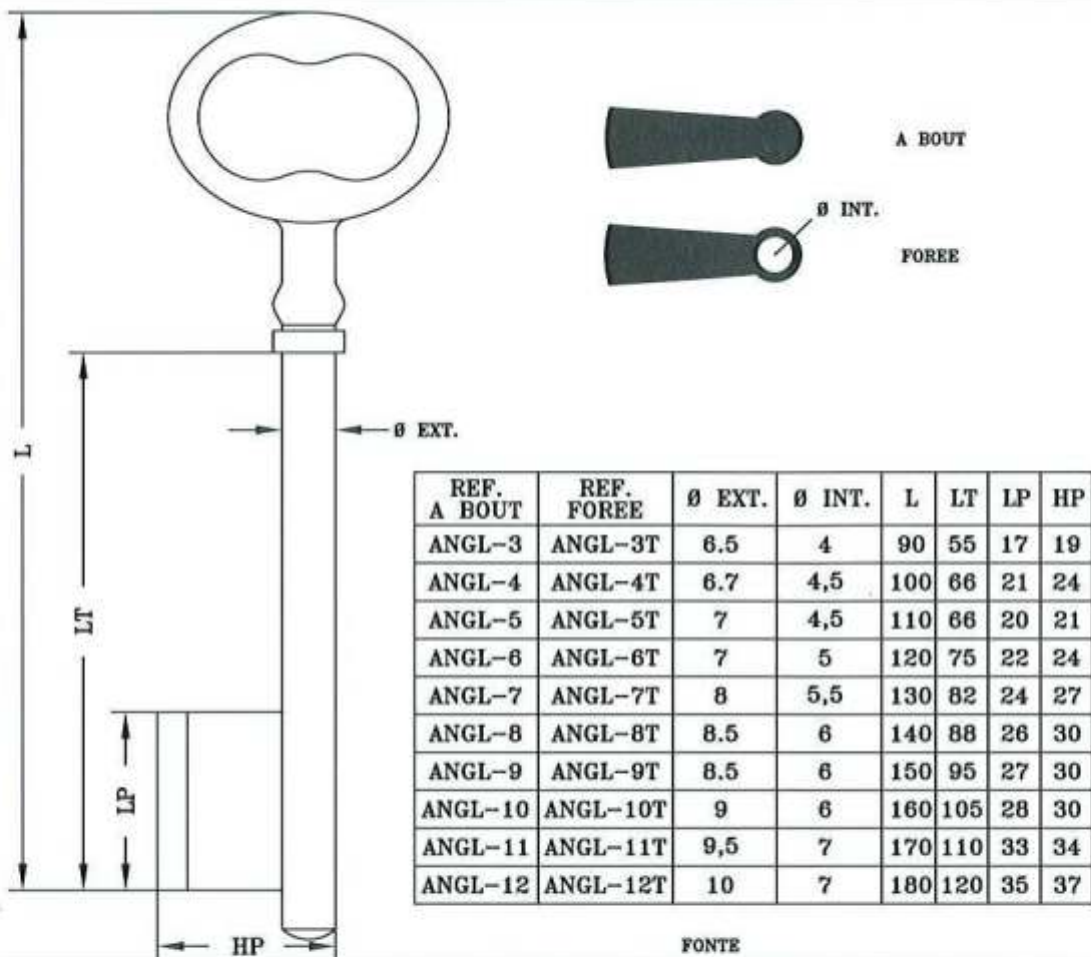

## PANNETON A MUSEAU

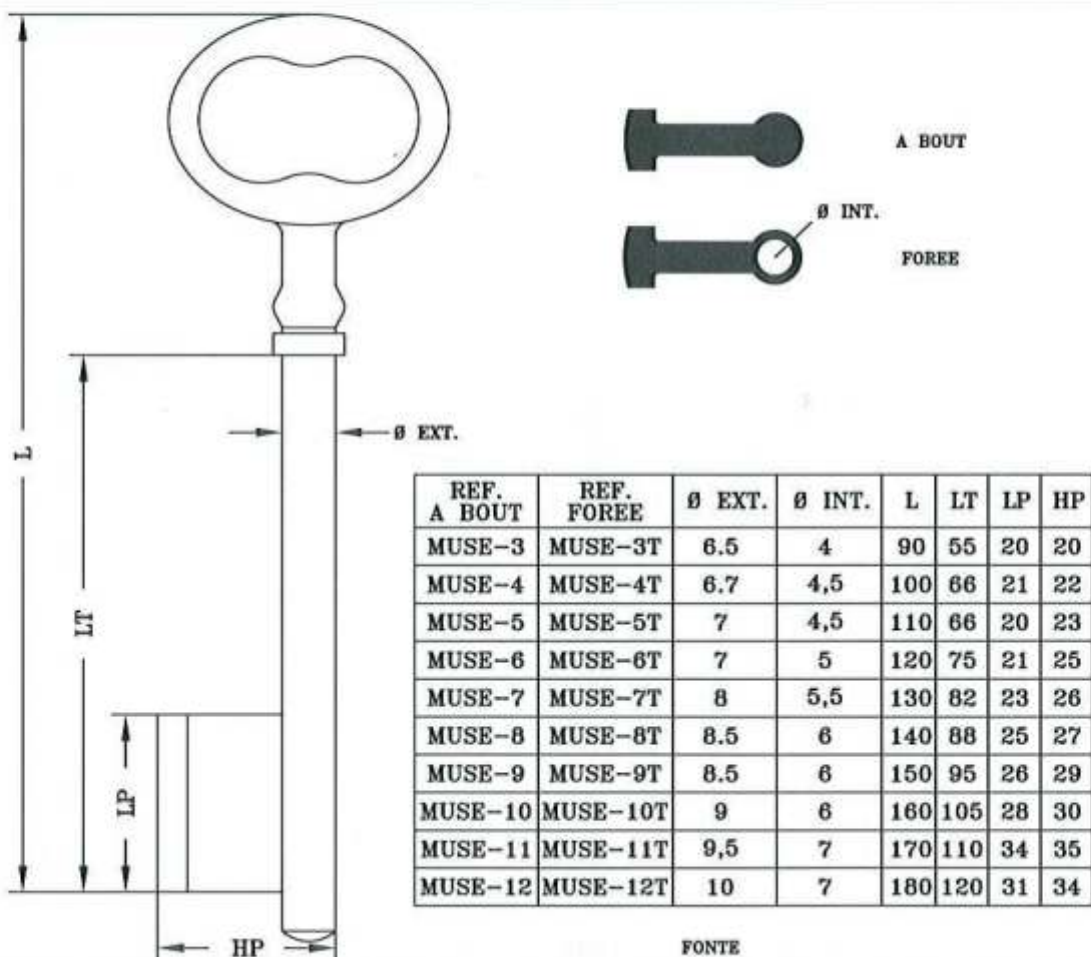

Copyright by  
Alejandro Altuna S.A.  
2011

**JMA**

21

# PANNETON PLEIN

POUR:

PICARDIE (F)

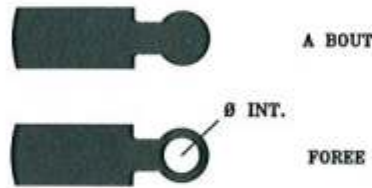
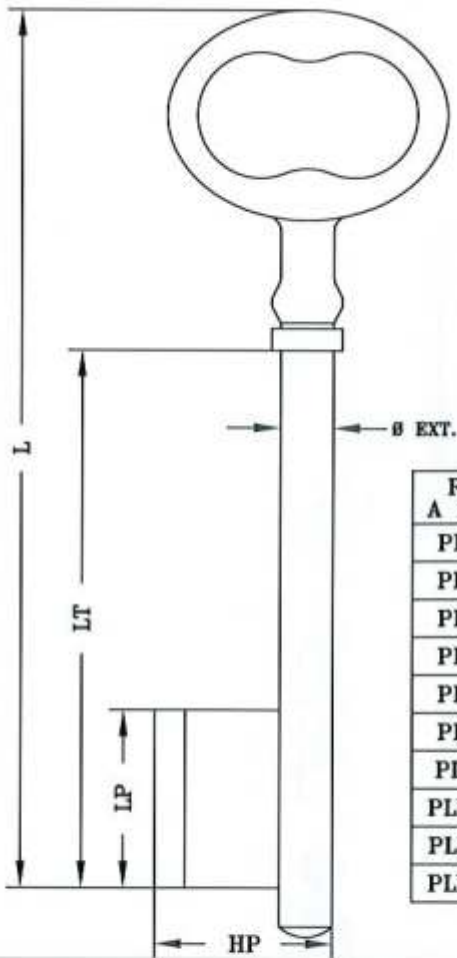

REF. A BOUT	REF. FOREE	Ø EXT.	Ø INT.	L	LT	LP	HP
PLE-3	PLE-3T	6.5	4	90	55	17	20
PLE-4	PLE-4T	6.7	4,5	100	66	20	23
PLE-5	PLE-5T	7	4,5	110	66	20	21
PLE-6	PLE-6T	7	5	120	75	22	24
PLE-7	PLE-7T	8	5,5	130	82	24	26
PLE-8	PLE-8T	8.5	6	140	88	24	28
PLE-9	PLE-9T	8.5	6	150	95	27	30
PLE-10	PLE-10T	9	6	160	105	28	31
PLE-11	PLE-11T	9,5	7	170	110	29	33
PLE-12	PLE-12T	10	7	180	120	30	33

FORTE

## CLES ADAPTABLES A CHIFFRES "PICARDIE" EN FORTE

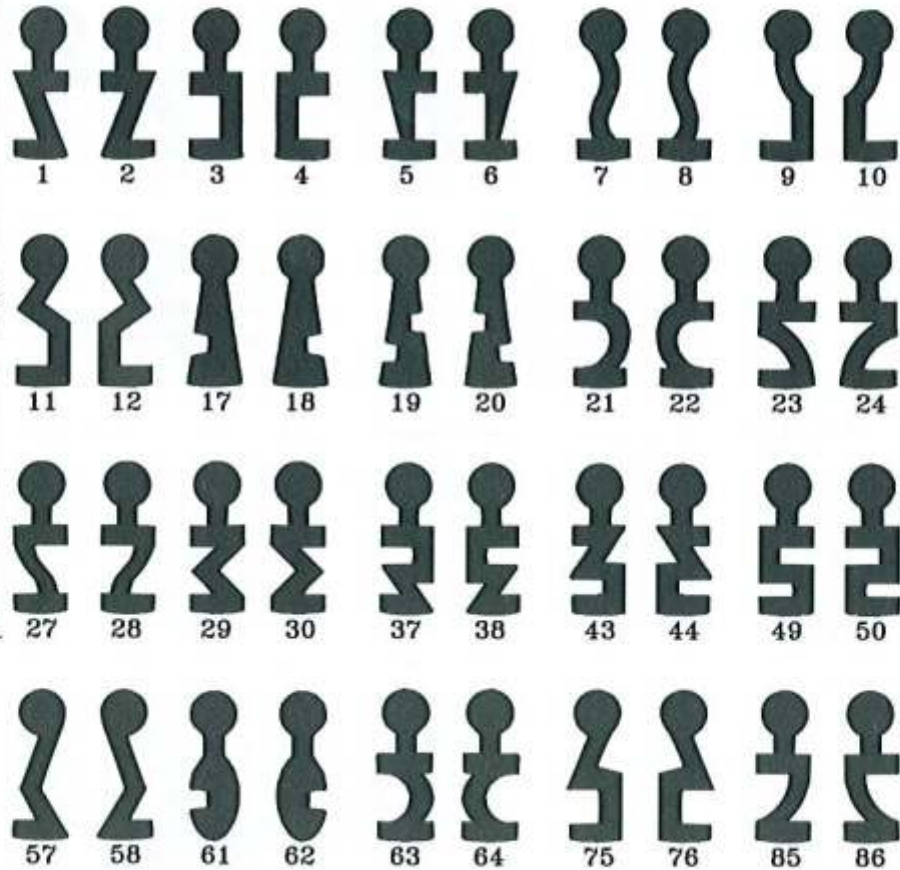
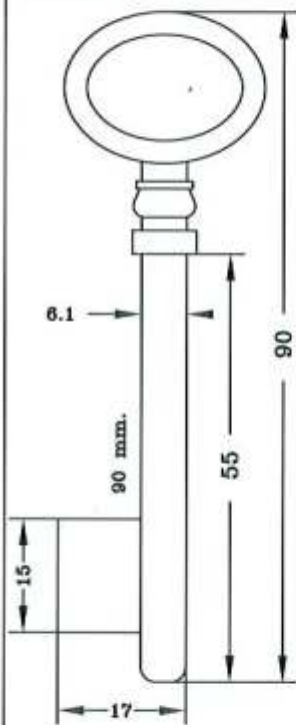

PIC-1F--  
SUBSTITUTION ADPLE-22  
FORTE

Copyright by  
Alejandro Altuna S.A.  
2011

**JMA**

22

POUR:

PICARDIE (F)

UNION (GB)

# CLES ADAPTABLES A CHIFFRES "PICARDIE" EN FONTE

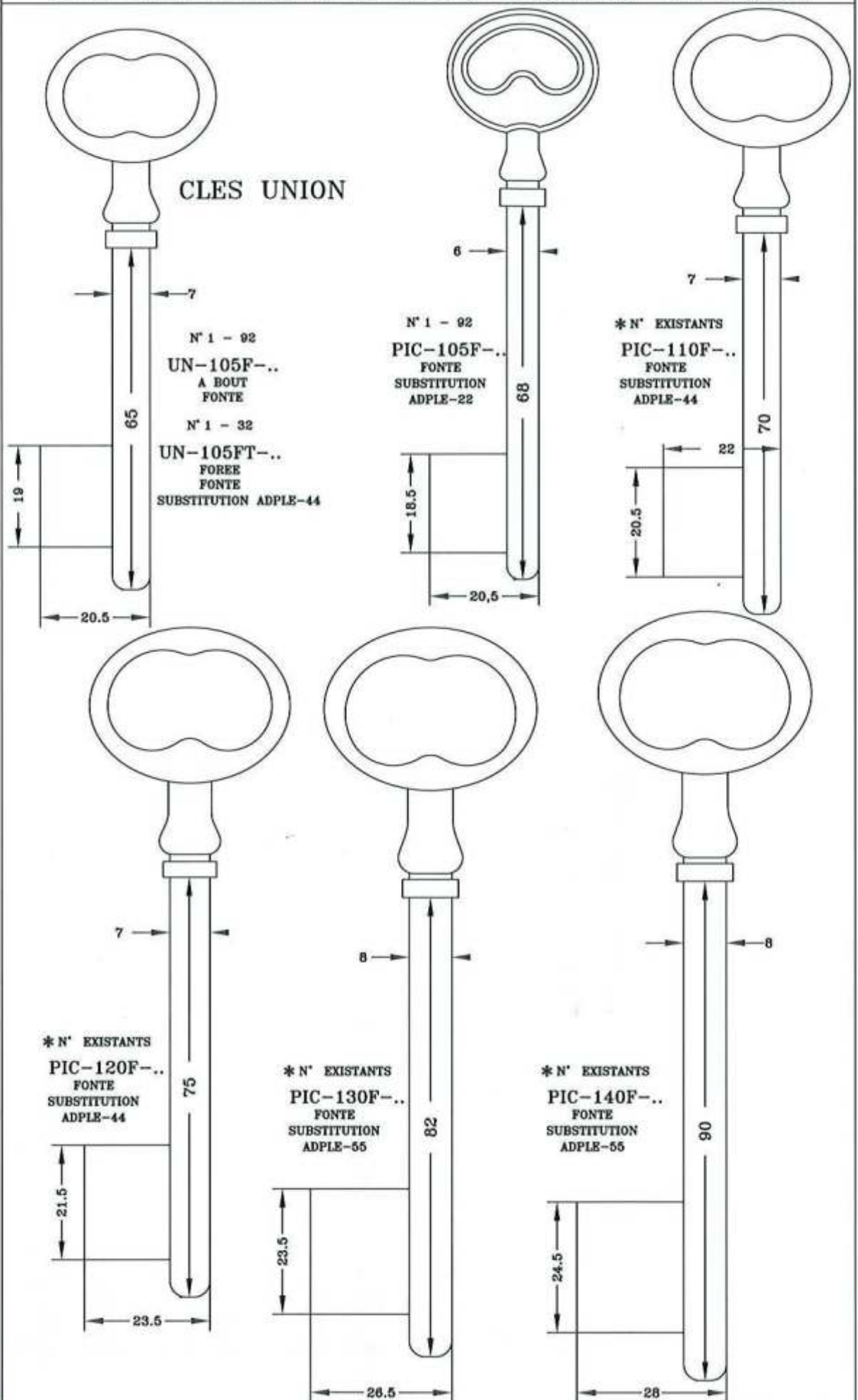

Copyright by  
Alejandro Altuna S.A.  
2011

**JMA**

VARIURES SERIES PICARDIE ET UNION

POUR:

PICARDIE (F)

UNION (GB)

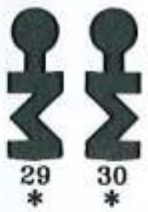

UTILISER  
25 26



UTILISER  
49 50

UTILISER  
49 50

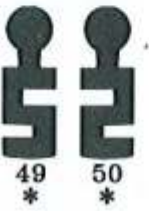

UTILISER  
21 22



UTILISER  
21 22

UTILISER  
21 22



UTILISER  
21 22

Copyright by  
Alejandro Altuna S.A.  
2011

**JMA**

POUR:

SURETE POUSSEE

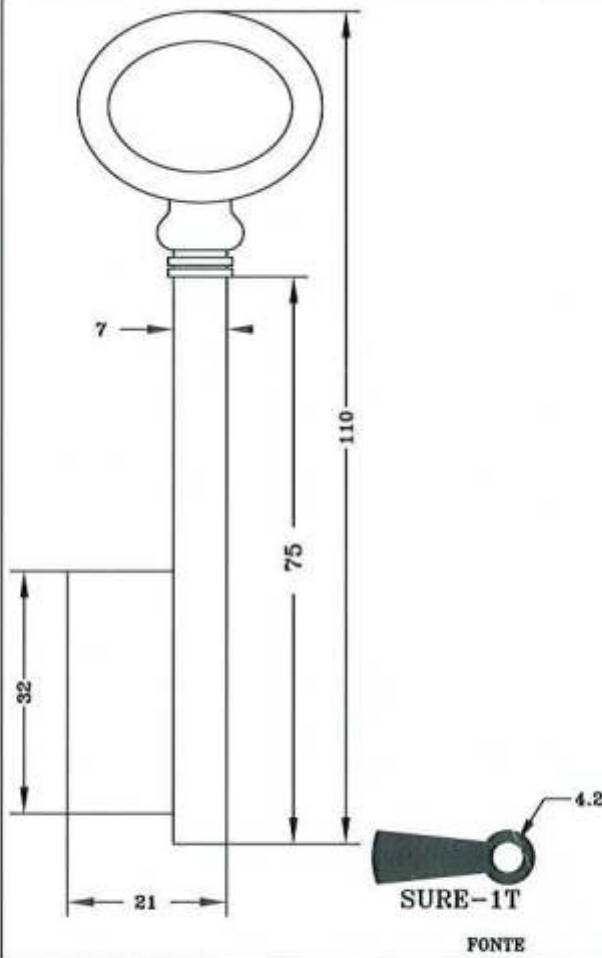

VERROU

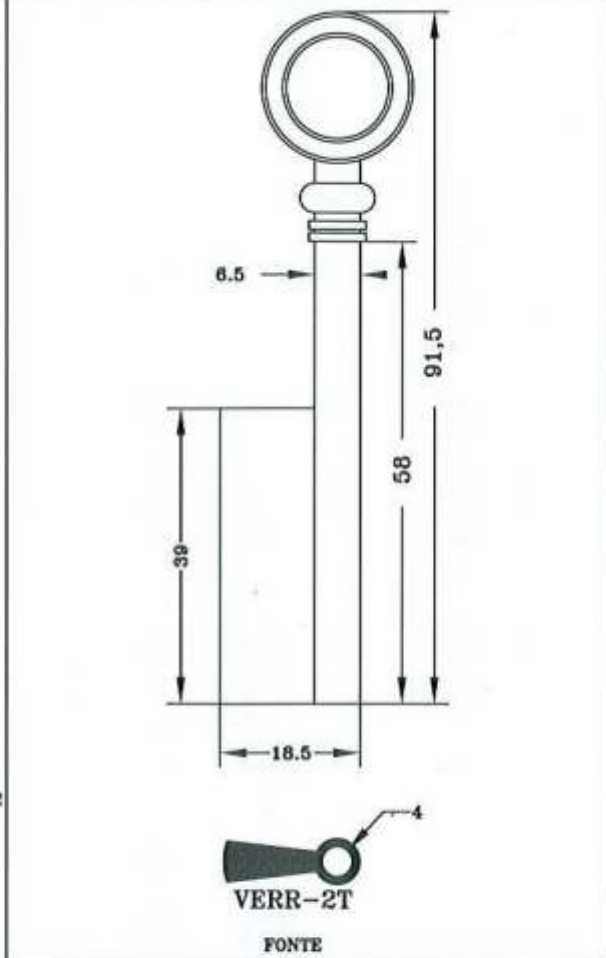

VERROU

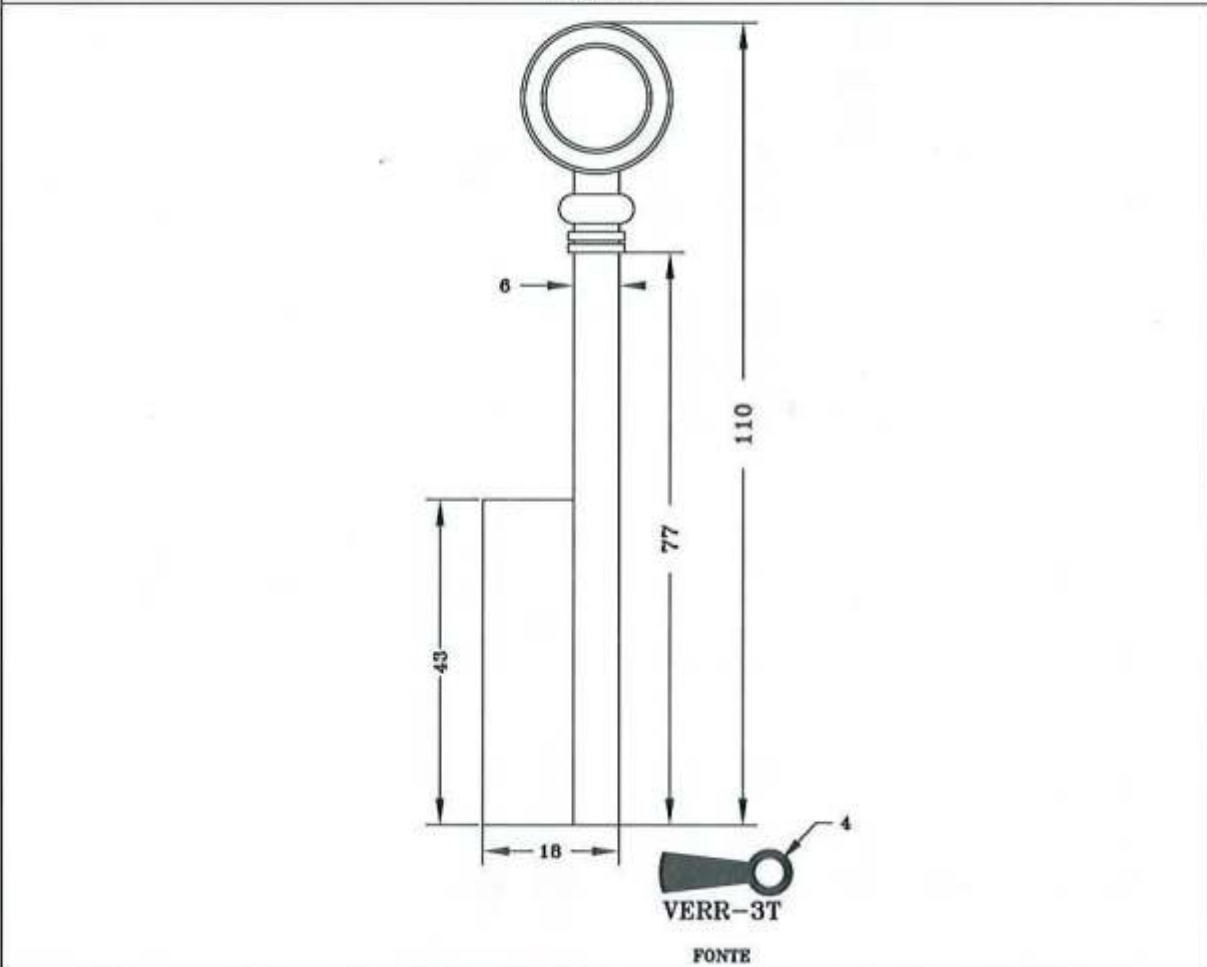

Copyright by  
Alejandro Altuna S.A.  
2011

**JMA**

25

***CLES A GORGES ET A CHIFFRES  
PAR MARQUE DE SERRURE***



***THE KEY TO EXCELLENCE***  
GLOBALLY UNLOCKING MILLIONS OF DOORS DAILY

**POUR:**

AVA CHUBB (GB)

BODE (D)

BRICARD (F)

**AVA-CHUBB**

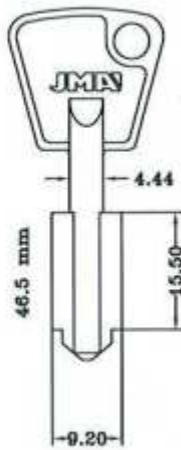

**CHU-4G**  
LAITON

**BODE**

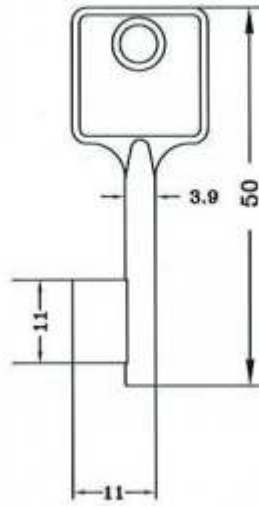

**BOE-1**  
LAITON

**BRICARD**

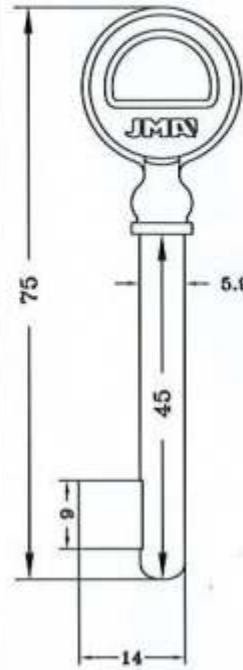

**BRI-1**  
LAITON

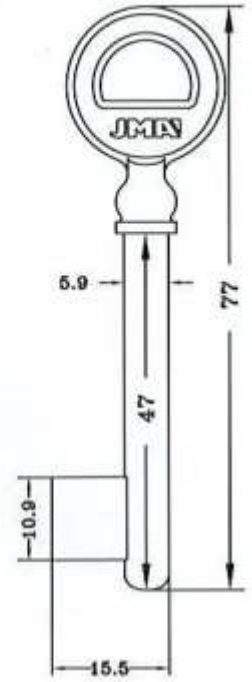

**BRI-2**  
LAITON

**BRICARD**

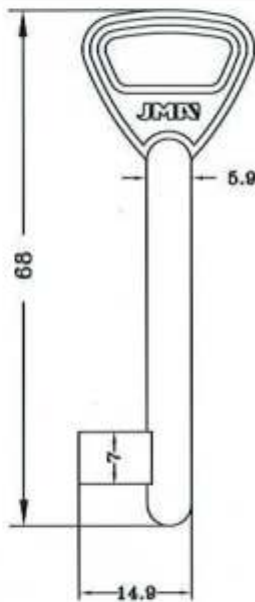

**BRI-3**  
LAITON

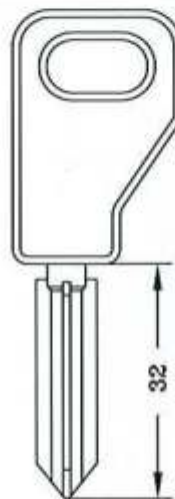

**BRI-1X**

**BRI-2X**

**BRI-3X**

LAITON

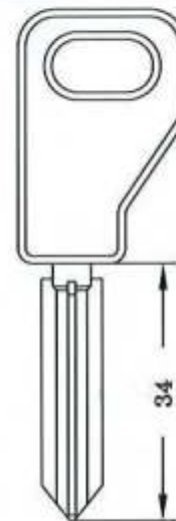

**BRI-4X**

**BRI-5X**

**BRI-6X**

LAITON

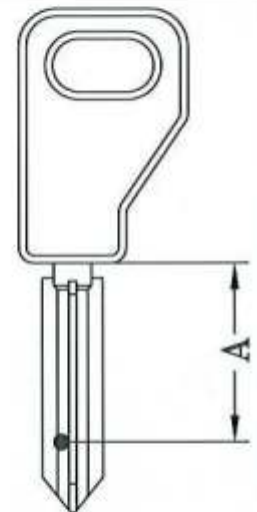

JMA	A
BRI-6XB1	27,4
BRI-6XB2	24,4
BRI-6XB3	21,4
BRI-6XB4	18,4

**BRI-6X**

LAITON

Copyright by  
Alejandro Altuna S.A.  
2011

**JMA**

27

POUR:

BRICARD (F)

DEBEAURAIN  
ND (F)

### BRICARD

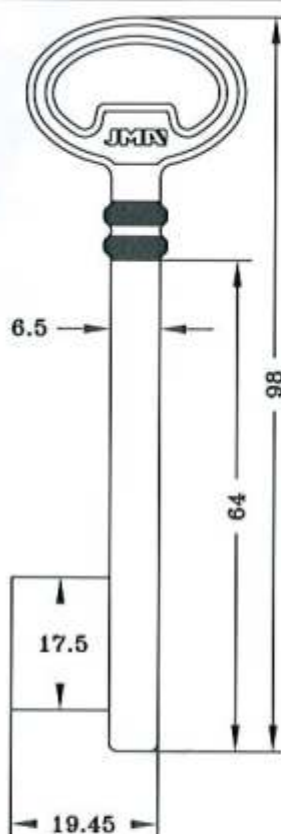
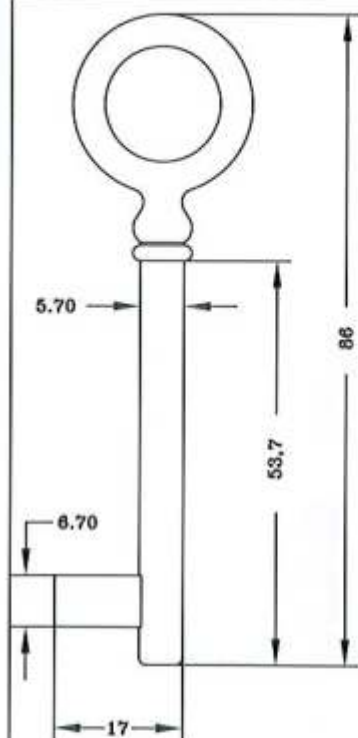

BRI-5F-..  
UTILISER ADPLE-11  
FONTE

SUBSTITUTION ADPLE-33  
BRI-6L...  
PETIT MALOIGNE  
LAITON

### DEBEAURAIN-ND

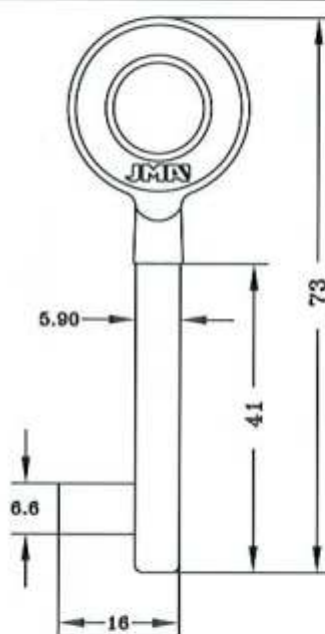
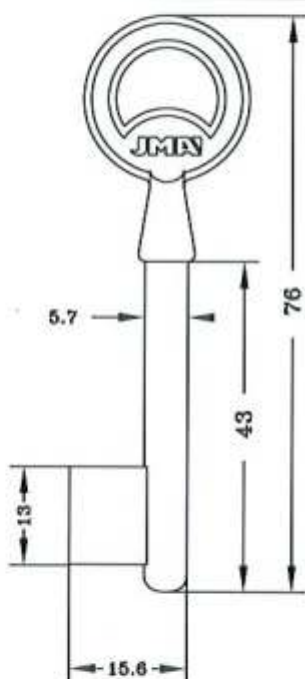
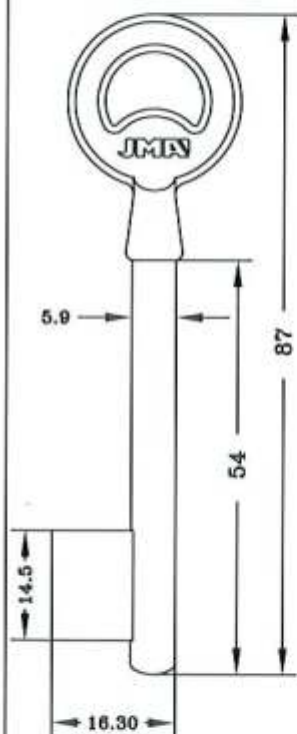

VARIETES  
LAPERCHE

LAP-3-..  
SUBSTITUTION ADPLE-22  
LAITON

Copyright by  
Alejandro Altuna S.A.  
2011

# JMA

POUR:

DEBEAURAIN  
ND (F)

DEBEAURAIN-ND

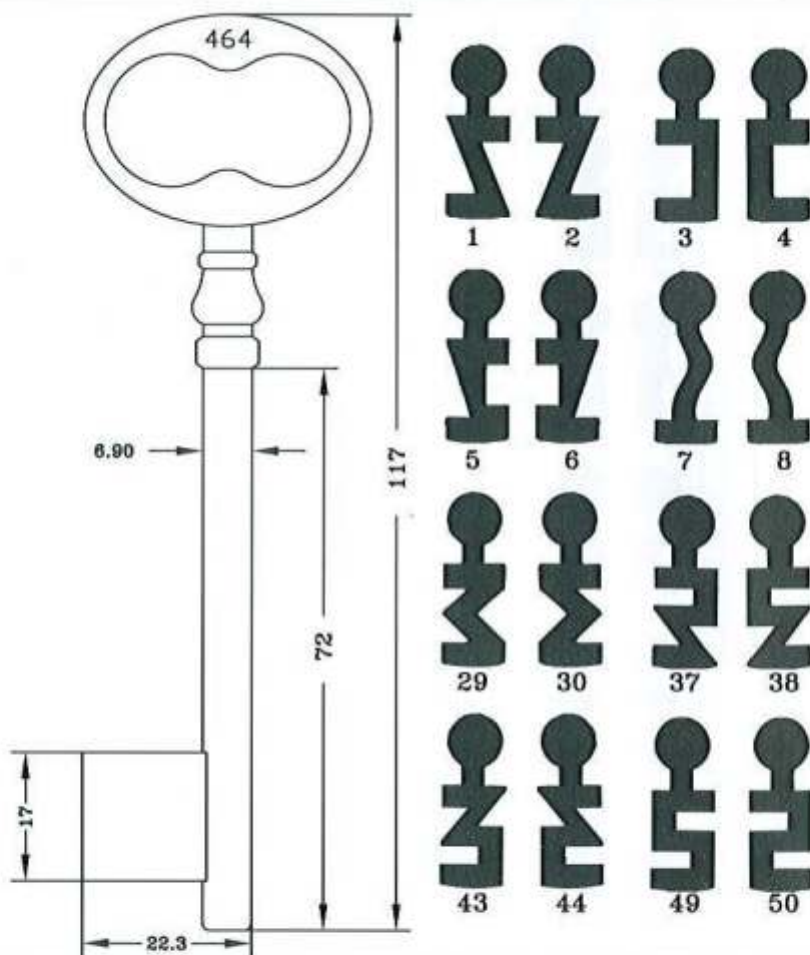

DEB-4F-..  
SUBSTITUTION ADPLE-44  
FONTE

DEBEAURAIN-ND

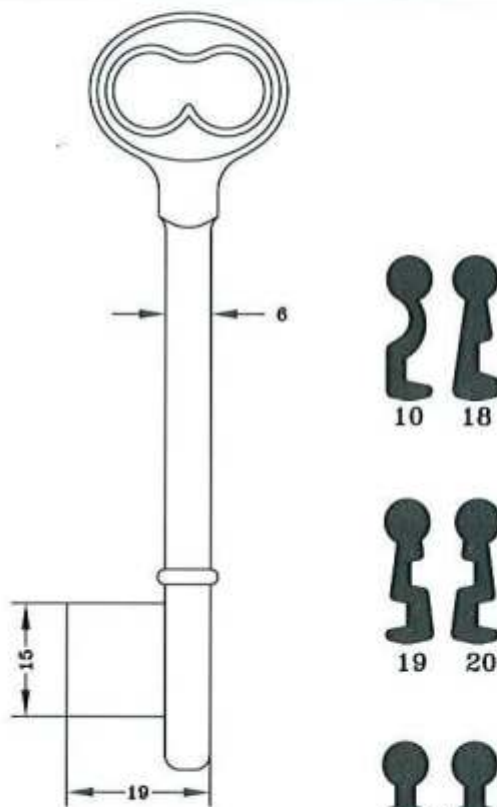

DEB-5CL-.. LAITON

Copyright by  
Alejandro Altuna S.A.  
2011

**JMA**

29

DEBEAURAIN-ND

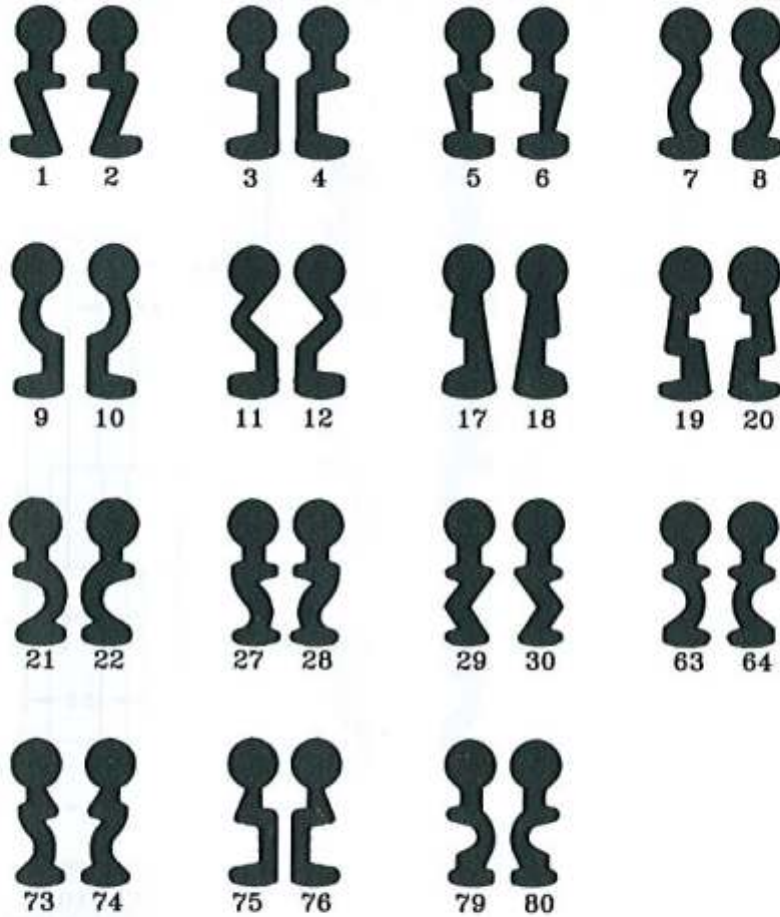
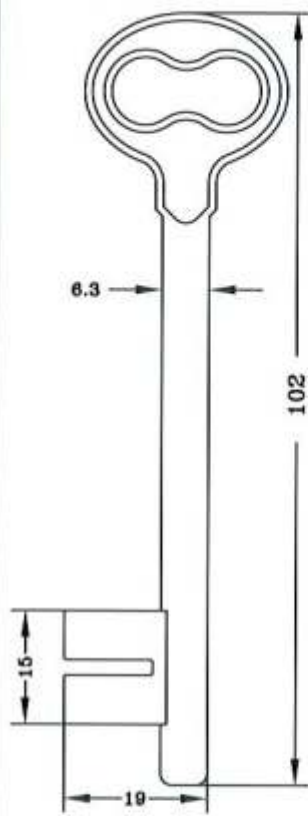

DEB-5L-... LAITON  
SUBSTITUTION ADPLE-22

POUR:

DEBEAURAIN  
ND (F)

DEBEAURAIN-ND

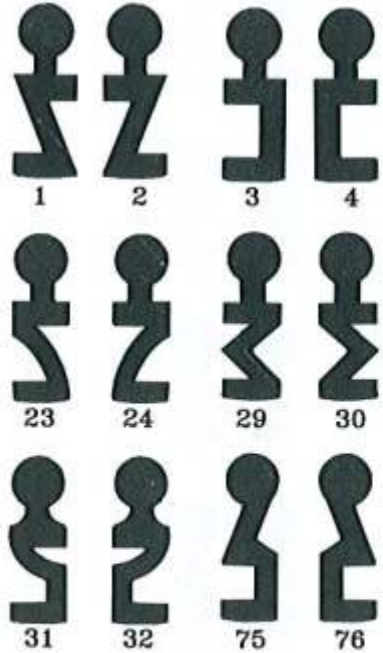
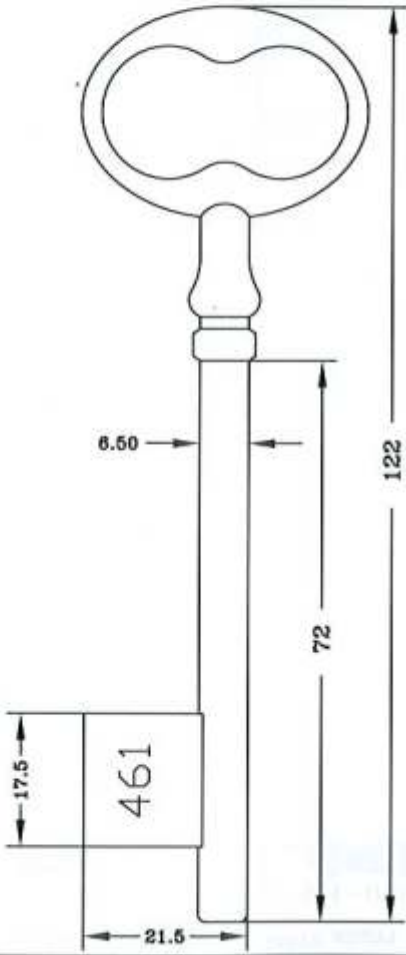

DEB-6F-...  
SUBSTITUTION ADPLE-33  
FONTE

Copyright by  
Alejandro Altuna S.A.  
2011

**JMA**

**30**

POUR:

DEBEAURAIN  
ND (F)

DECAYEUX  
DAD (F)

DEBEAURAIN-ND

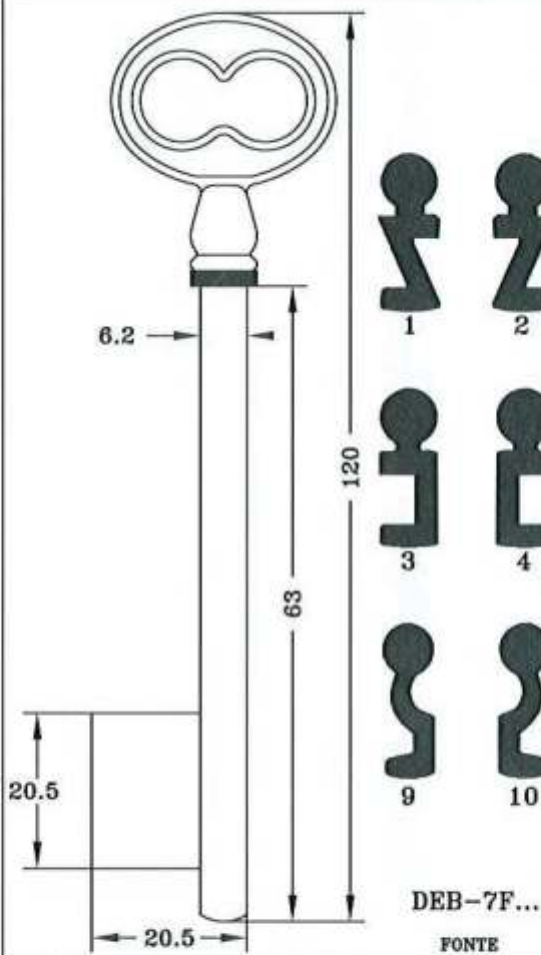

DEB-7F...  
FONTE

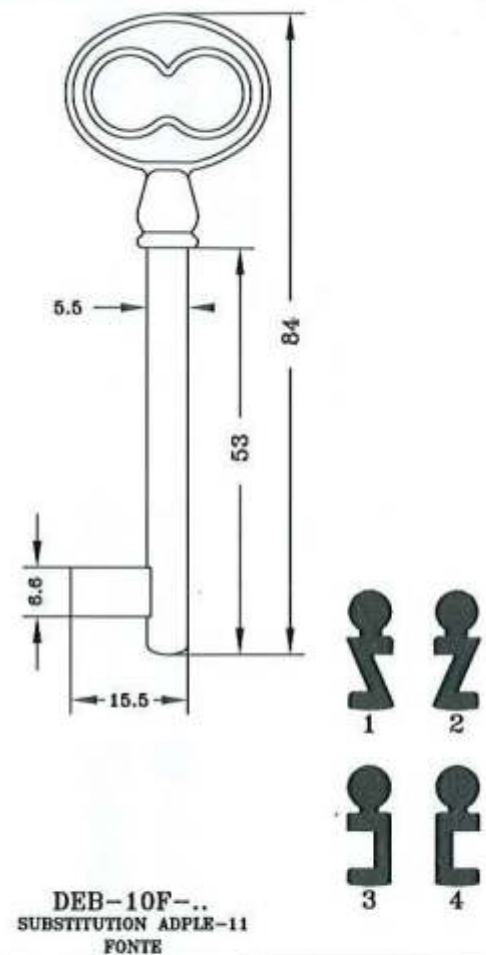

DEB-10F-..  
SUBSTITUTION ADPLE-11  
FONTE

DEBEAURAIN-ND

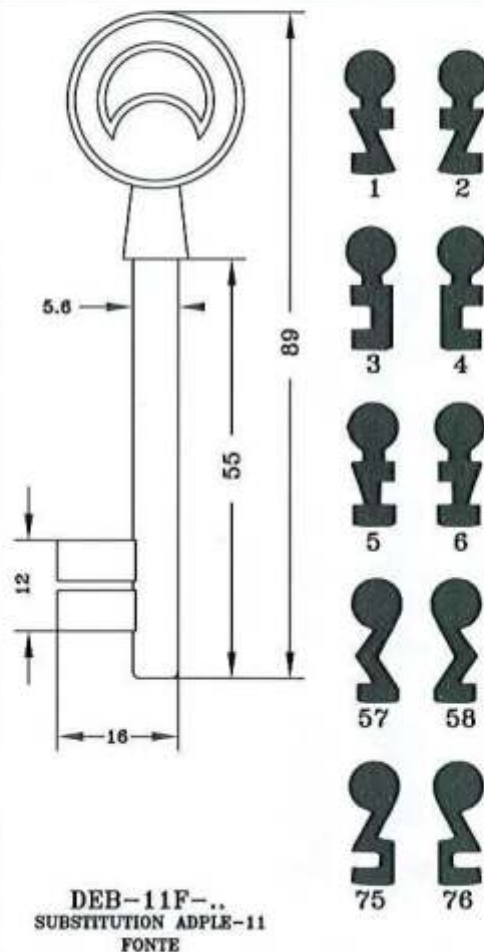

DEB-11F-..  
SUBSTITUTION ADPLE-11  
FONTE

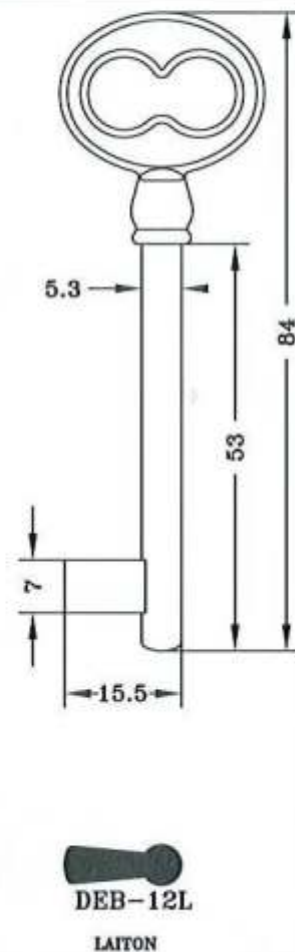

DEB-12L  
LAITON

DECAYEUX-DAD



DA-1  
LAITON

Copyright by  
Alejandro Altuna S.A.  
2011

**JMA**

31

POUR:

DENY (F)

EMERY (F)

FICHET (F)

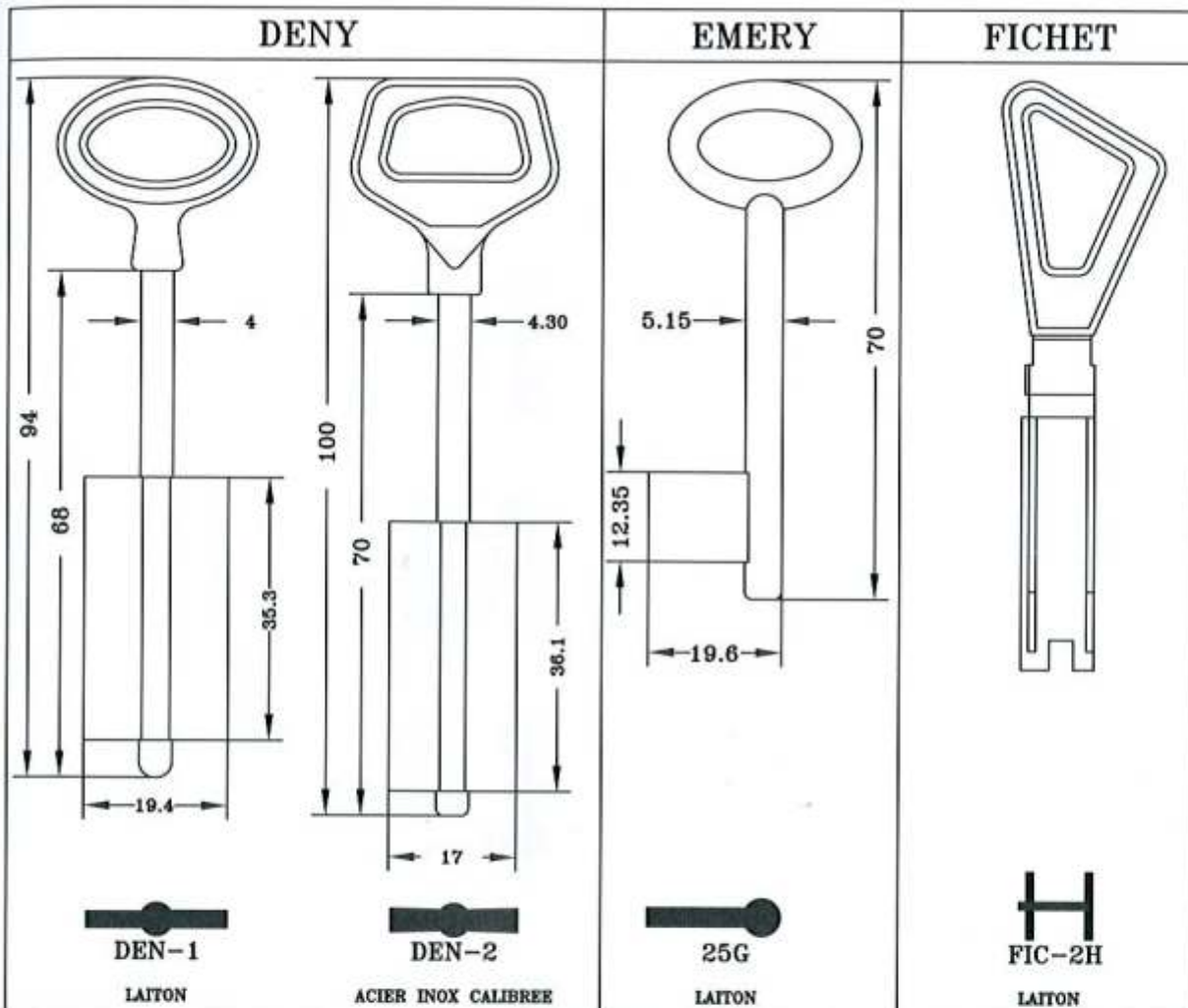

FICHET

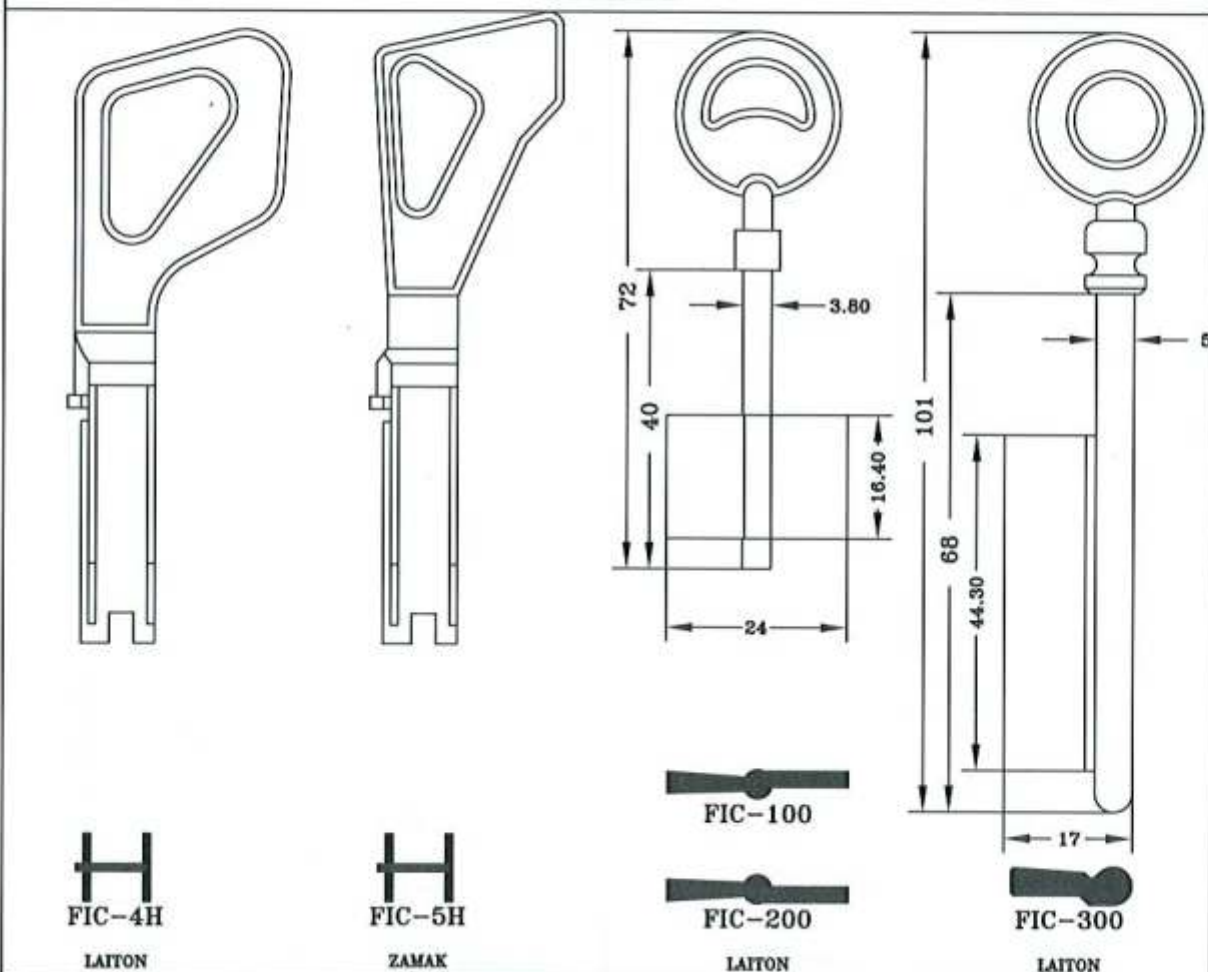

Copyright by  
Alejandro Altuna S.A.  
2011

**JMA**

32

POUR:

FICHET (F)

FTH (F)

## FICHET

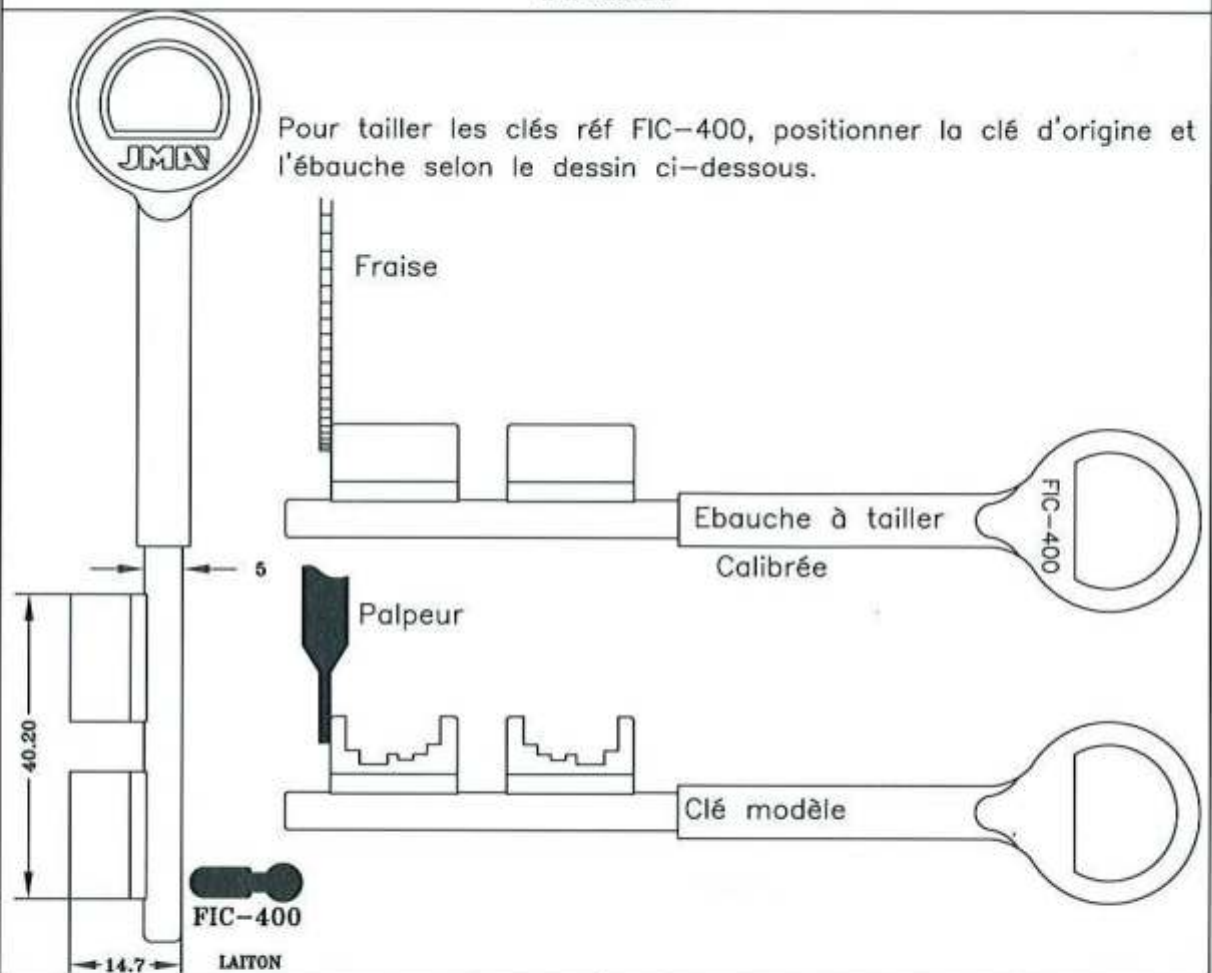

## FICHET

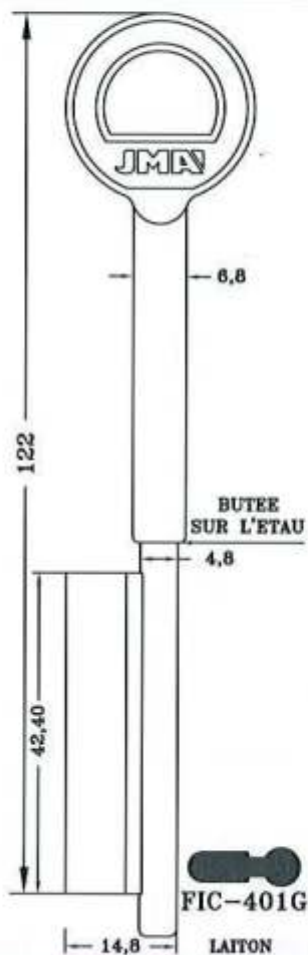

## FTH

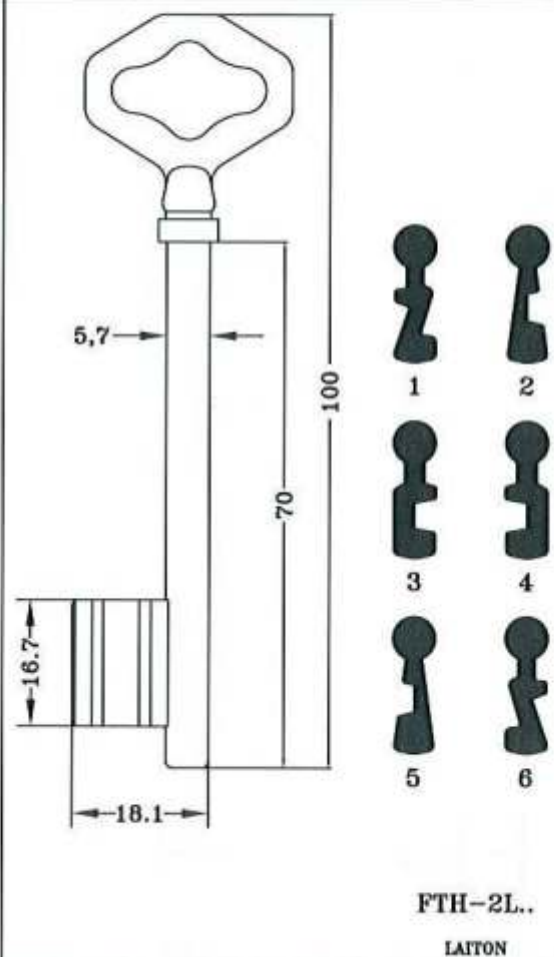

Copyright by  
Alejandro Altuna S.A.  
2011

**JMA**

33

POUR: \_\_\_\_\_

FTH

GOLLOT

FTH (F)

GOLLOT (F)

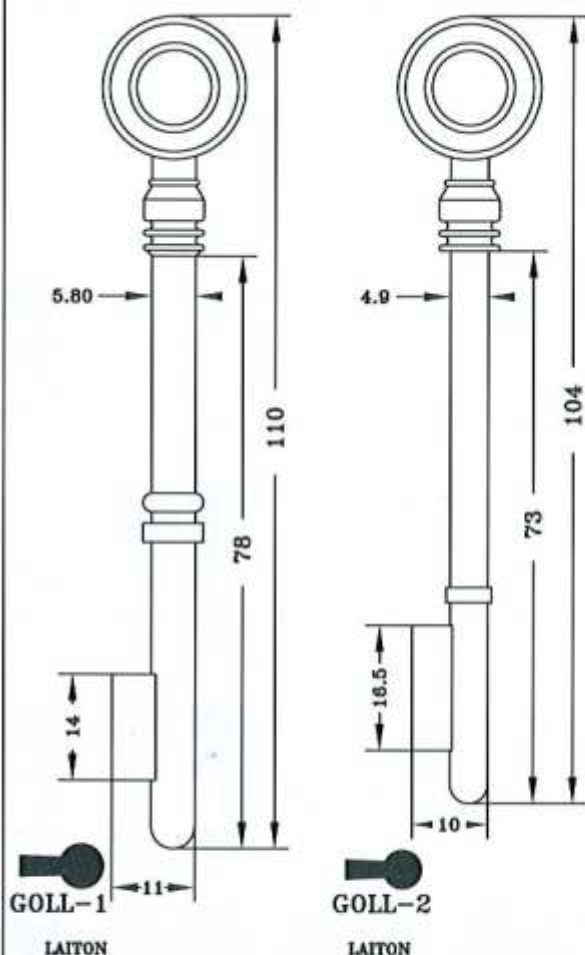
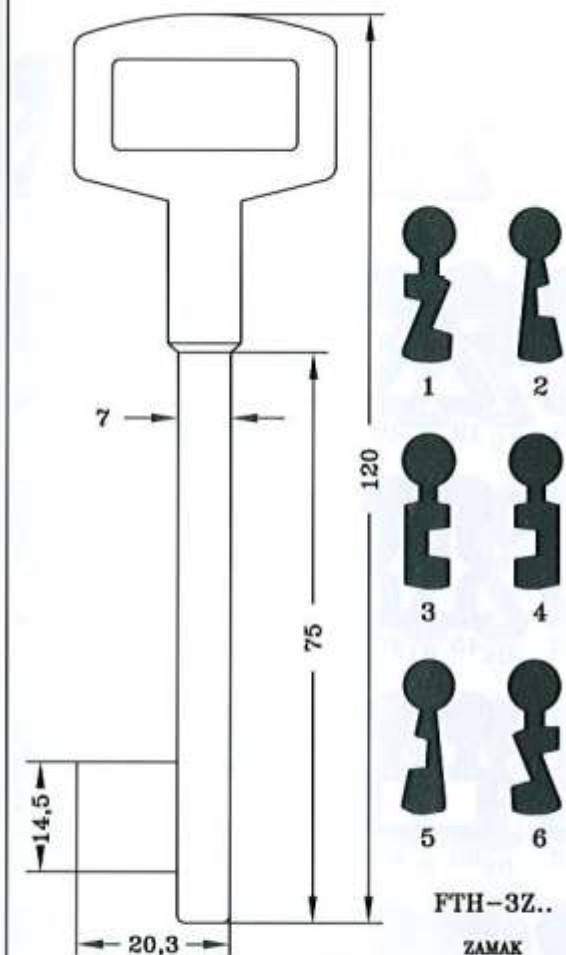

GOLLOT

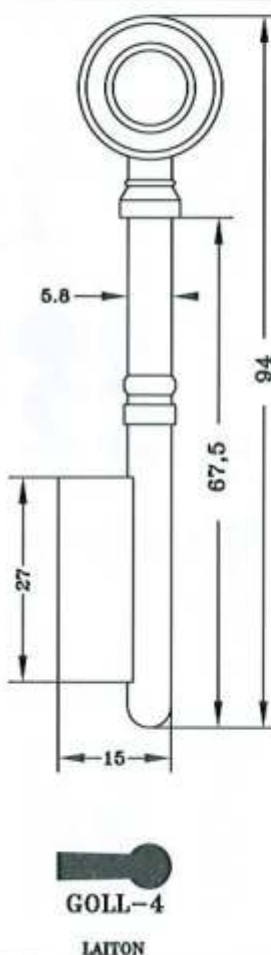
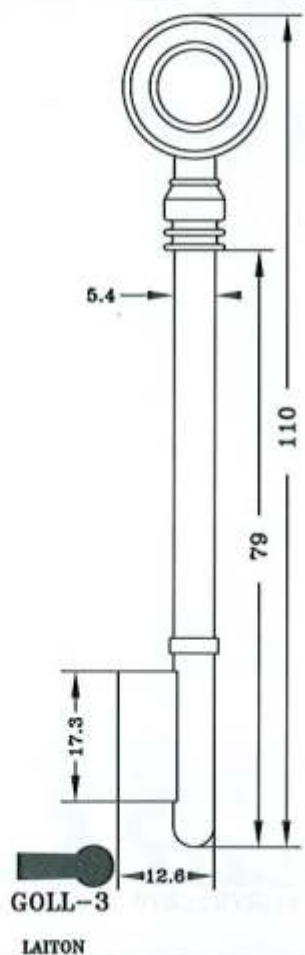

Copyright by  
Alejandro Altuna S.A.  
2011

**JMA**

**34**



UNIVERSAL - EN APPLIQUE

POUR: \_\_\_\_\_

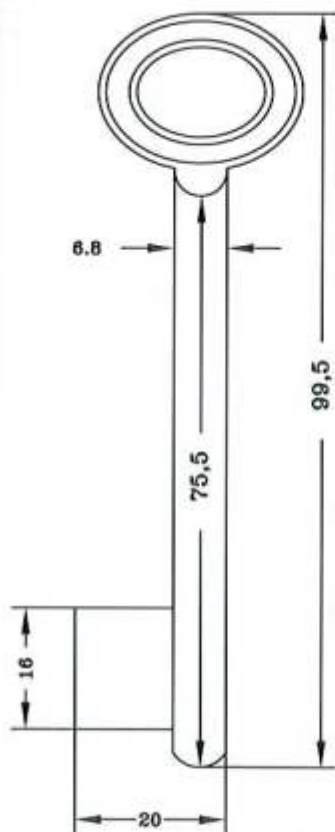

GTV-2F-...  
SUBSTITUTION ADPLE-33  
FONTE

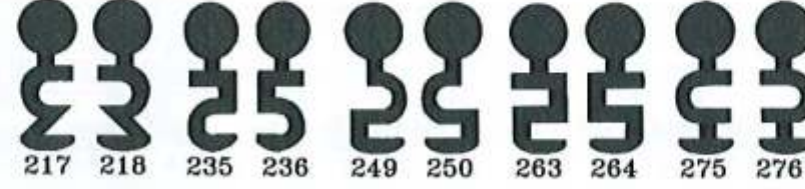
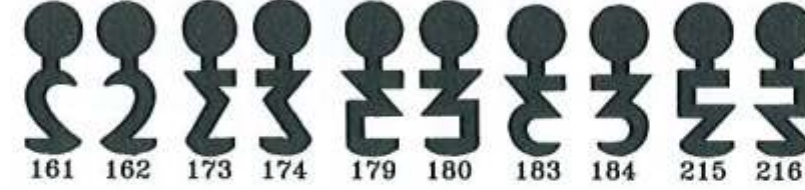
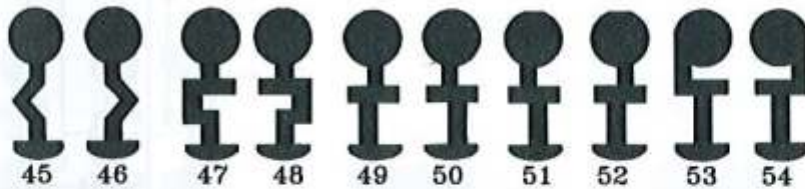

Copyright by  
Alejandro Altuna S.A.  
2011

**JMA**

POUR:

JPM(F)

JPM

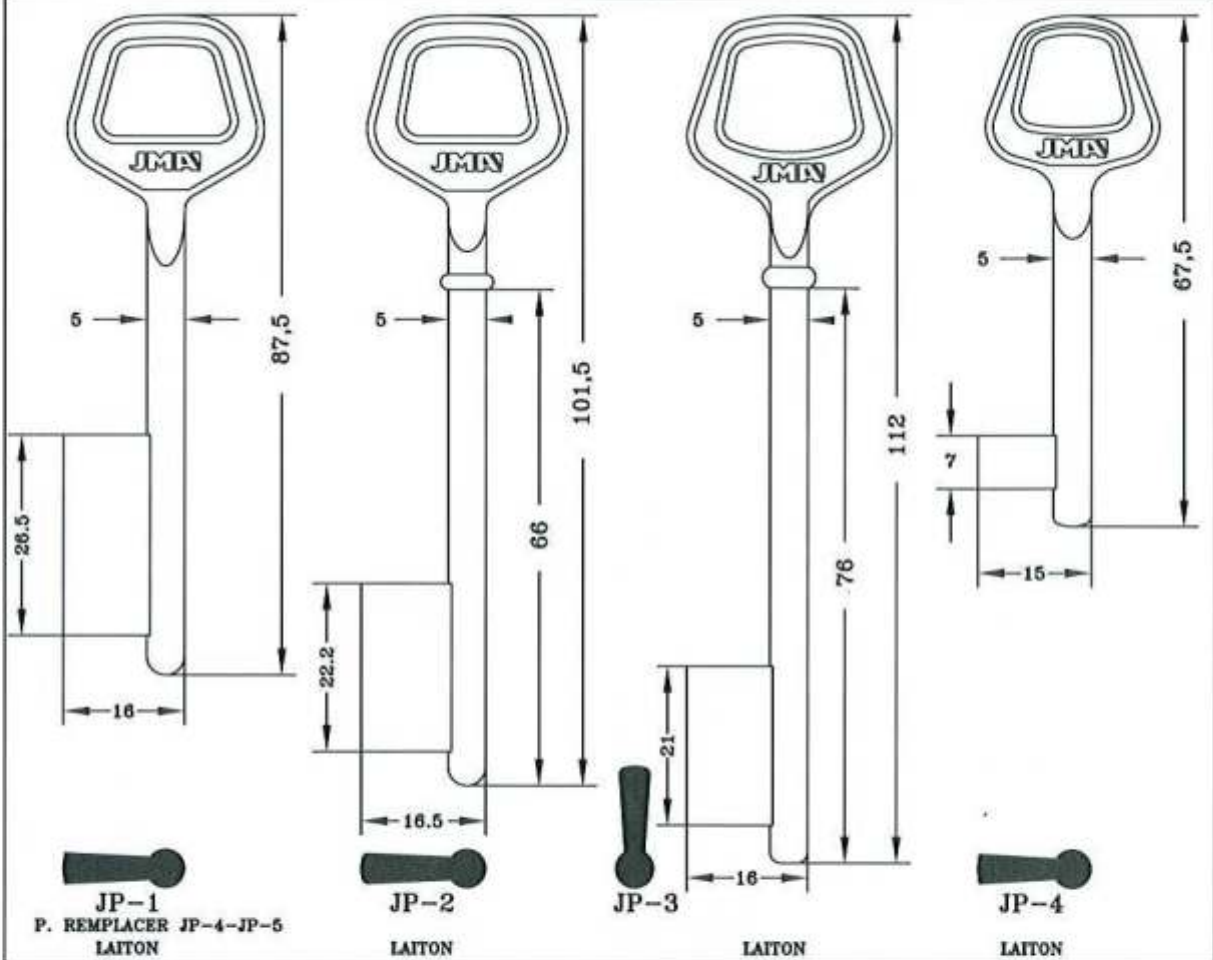

JPM

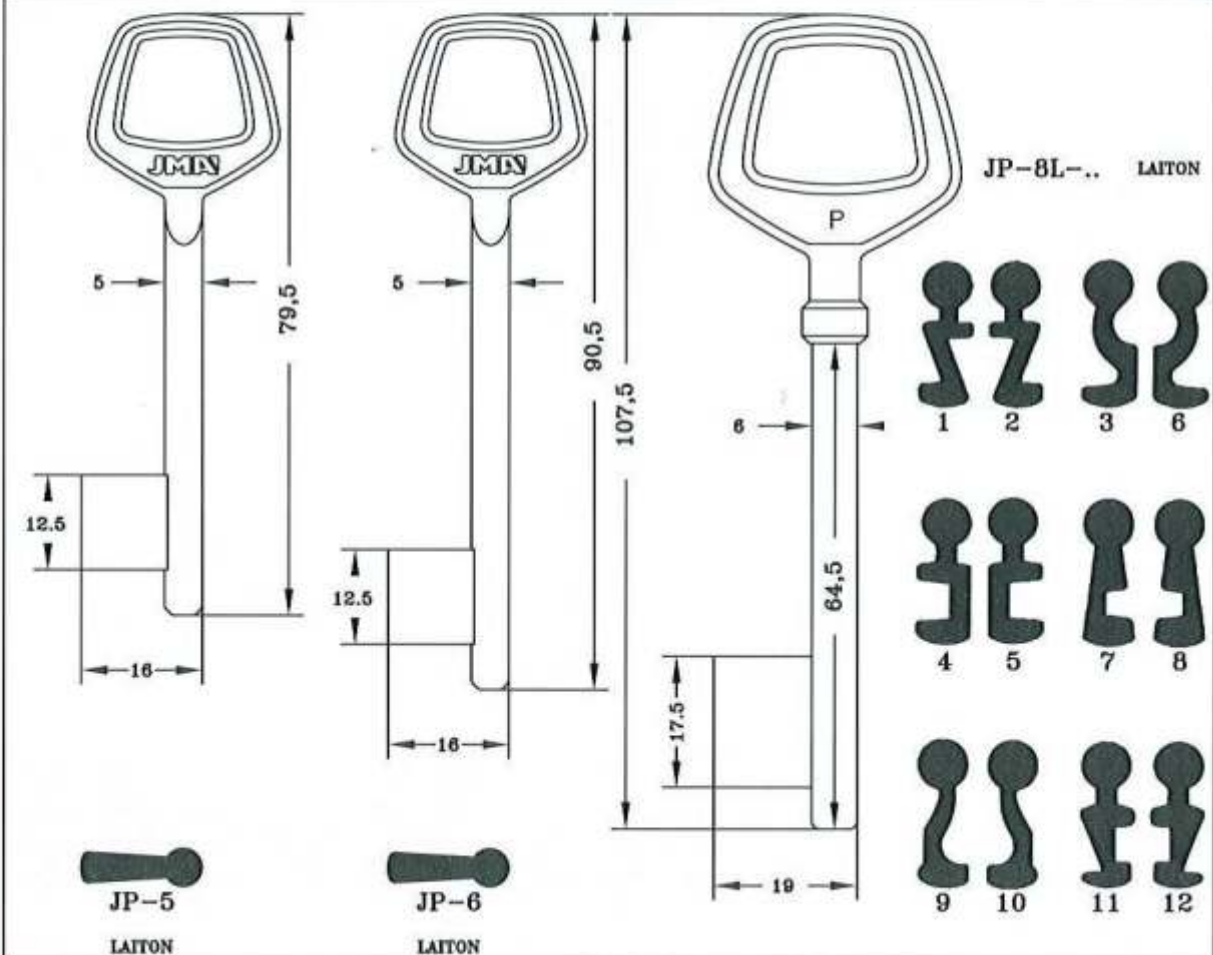

Copyright by  
Alejandro Altuna S.A.  
2011

**JMA**

37

POUR: \_\_\_\_\_

JPM (F)

KIMA (D)

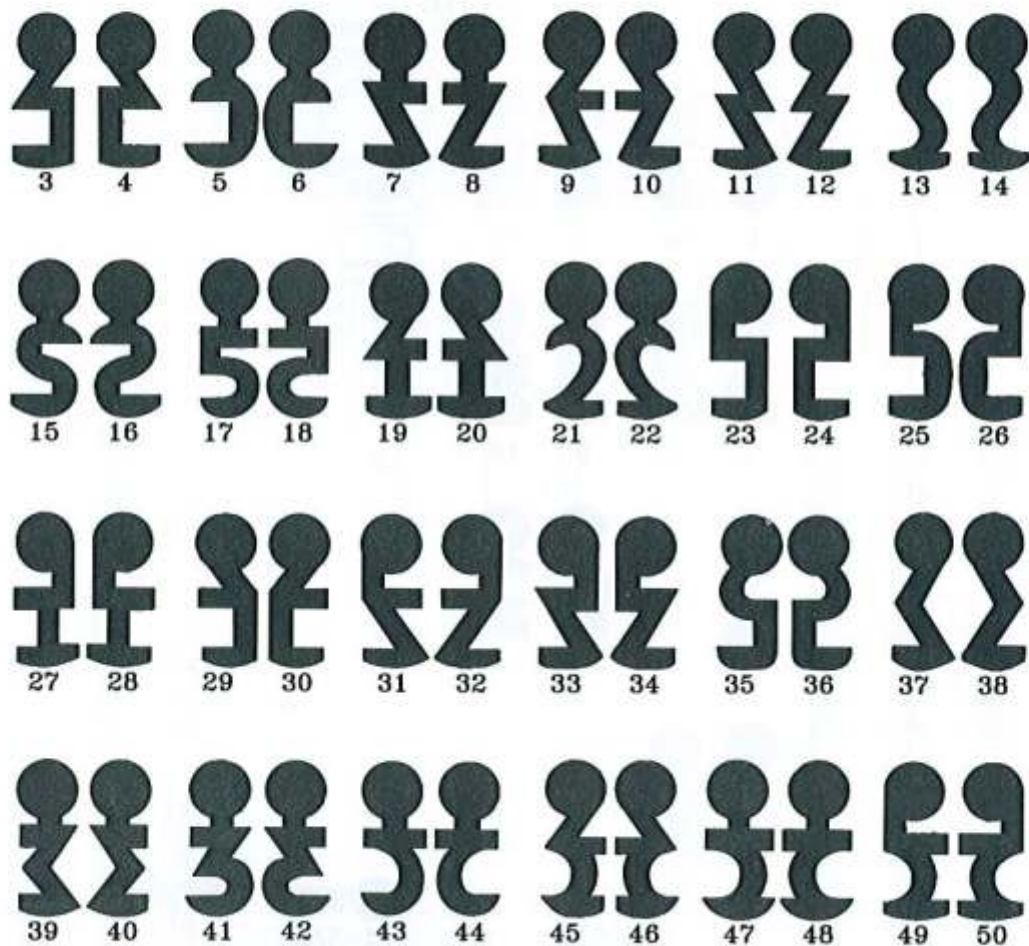
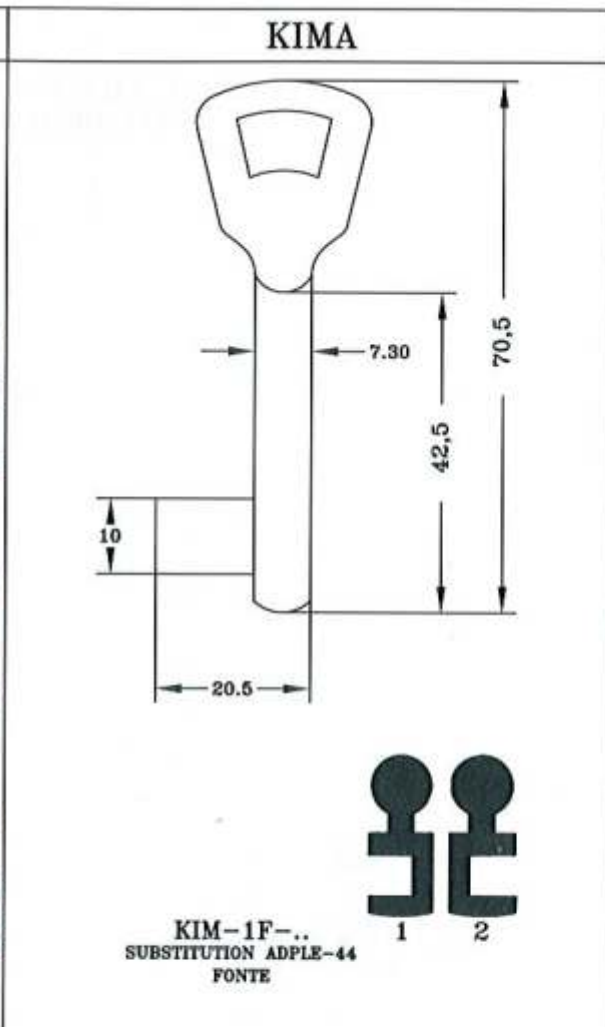
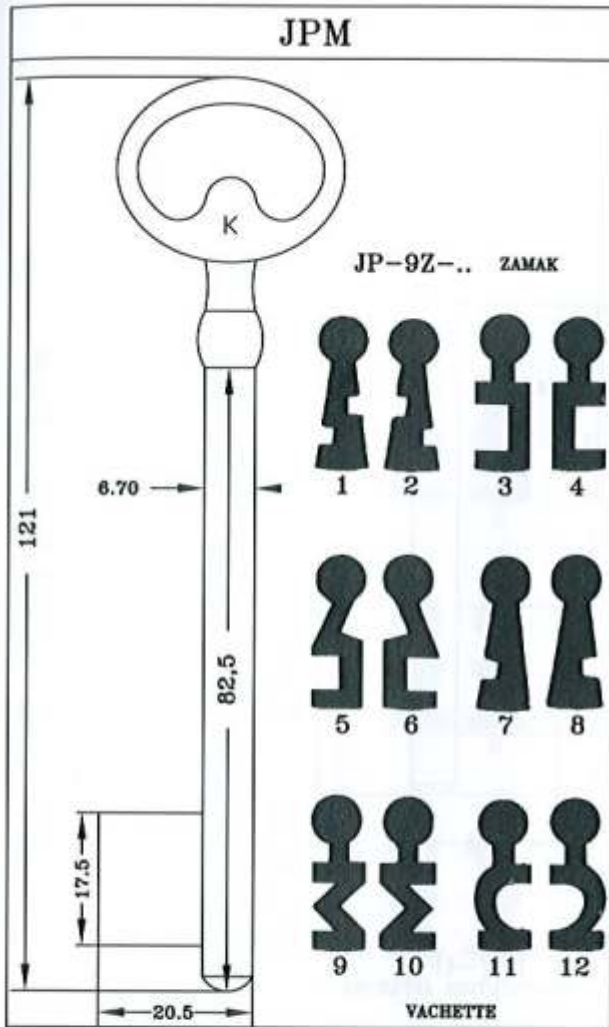

Copyright by  
Alejandro Altuna S.A.  
2011

**JMA**

POUR:

LAPERCHE (F)

LAPERCHE

CORRESPONDANCE VARIURES		
LAPERCHE		DEBEAURAIN
3		5
4		4
5		6
6		7
9		9
10		8

LAP-3 LAP-3-..  
LAITON LAITON

LAP-4F-..  
SUBSTITUTION ADPLE-22  
FONTE

LAPERCHE

SUBSTITUTION ADPLE-22

LAP-5F...  
STREMLER-VACHETTE  
FONTE

LAP-100  
LAITON

Copyright by  
Alejandro Altuna S.A.  
2011

**JMA**

39

# LAURENT

POUR:

LAURENT (F)

LEGGE (GB)

MAFOR (F)

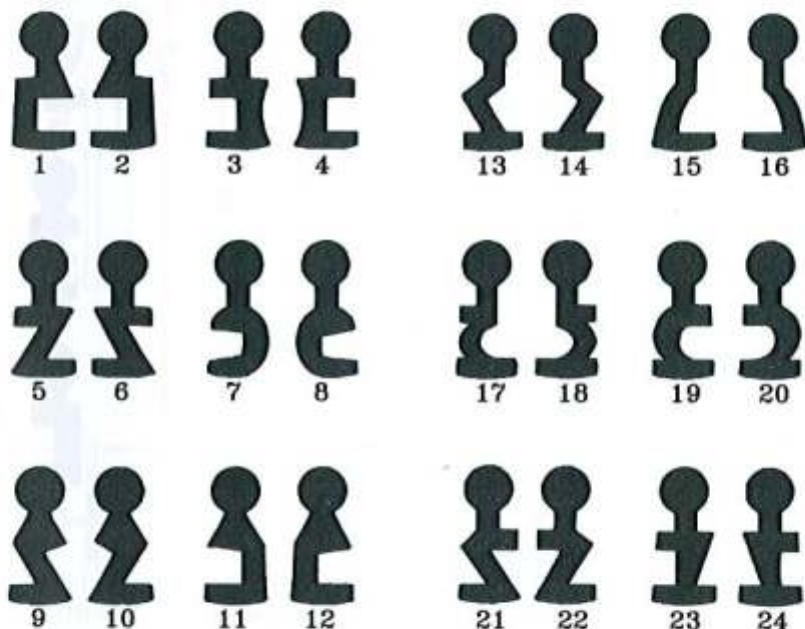
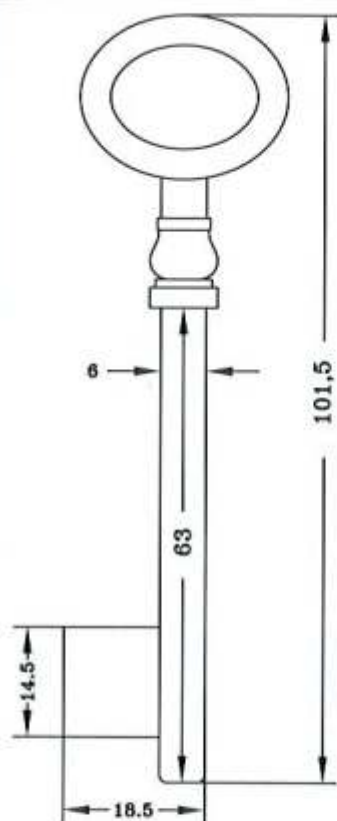

LAU-1Z-.. ZAMAK  
SUBSTITUTION ADPLE-22

## LEGGE

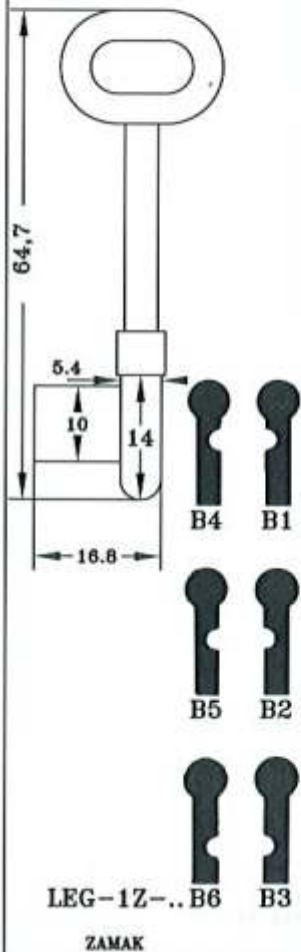

LEG-1Z-.. B6 B3  
ZAMAK

## MAFOR

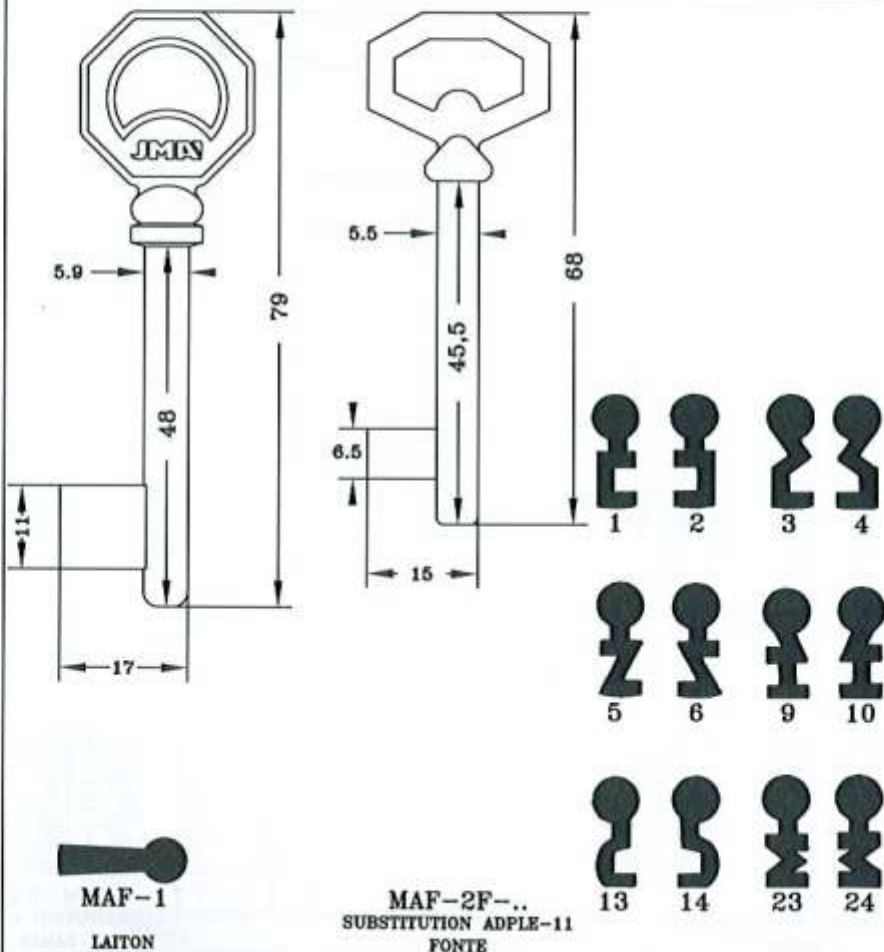

MAF-2F-..  
SUBSTITUTION ADPLE-11  
FONTE

Copyright by  
Alejandro Altuna S.A.  
2011

**JMA**

POUR:

MAFOR (F)

MERMIER (F)

MAFOR

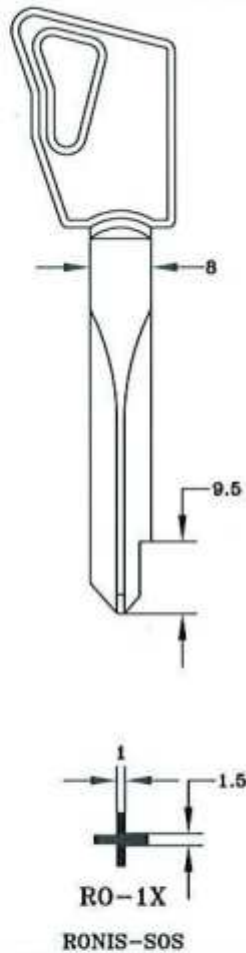

MERMIER

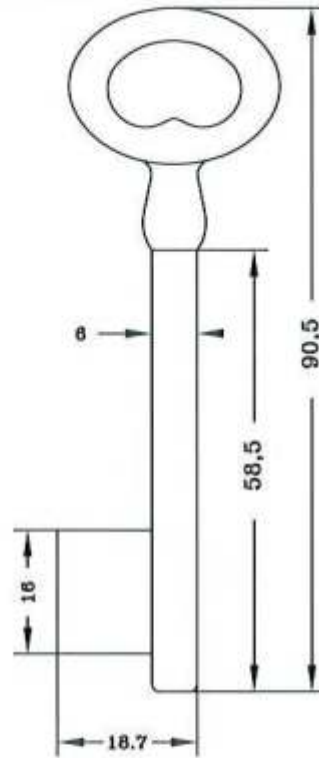

MRM-2Z-...ZAMAK  
SUBSTITUTION ADPLE-22

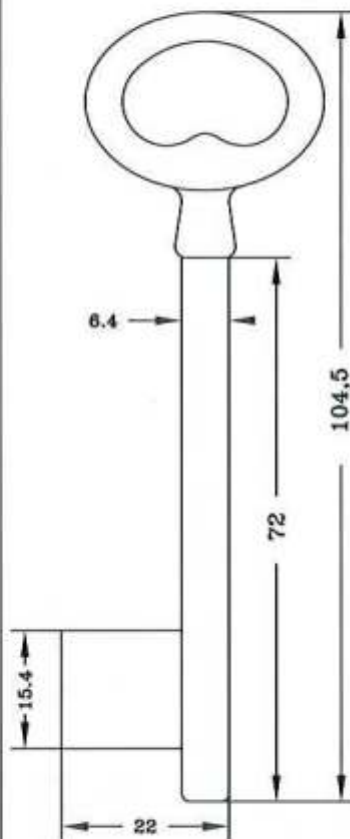

MRM-3Z-...  
SUBSTITUTION ADPLE-33  
ZAMAK

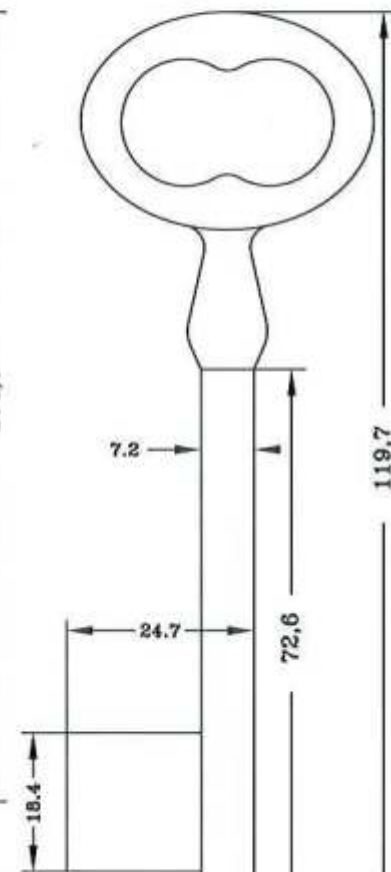

MRM-4Z-...  
SUBSTITUTION ADPLE-44  
ZAMAK

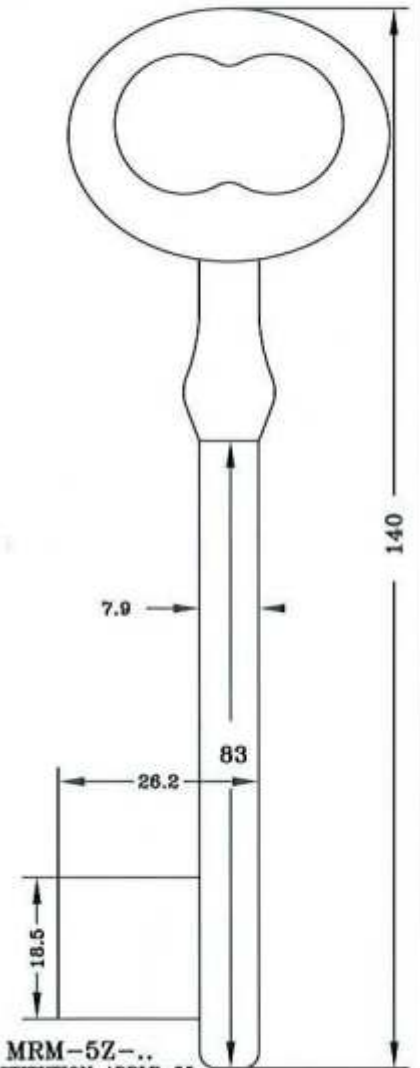

MRM-5Z-...  
SUBSTITUTION ADPLE-55  
ZAMAK

Copyright by  
Alejandro Altuna S.A.  
2011

**JMA**

41

**MOREAUX**

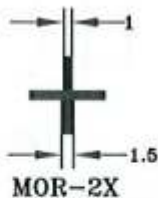
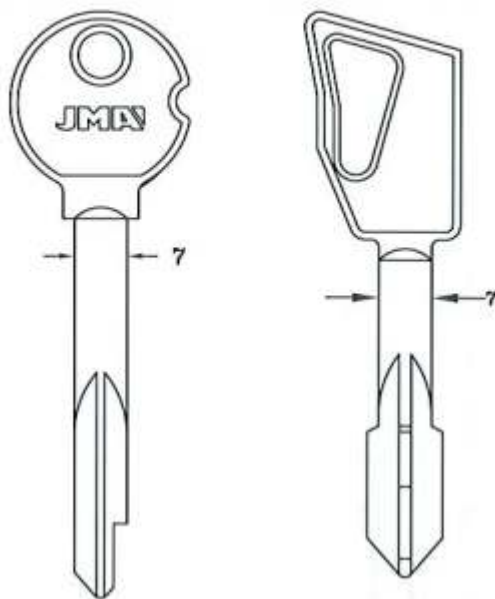

**MUEL**

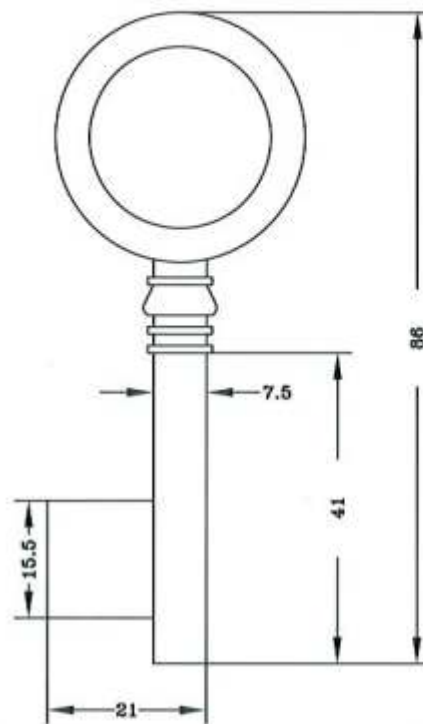

**POUR:**

MOREAUX (F)

MUEL (F)

NEMEF (NL)

**NEMEF**

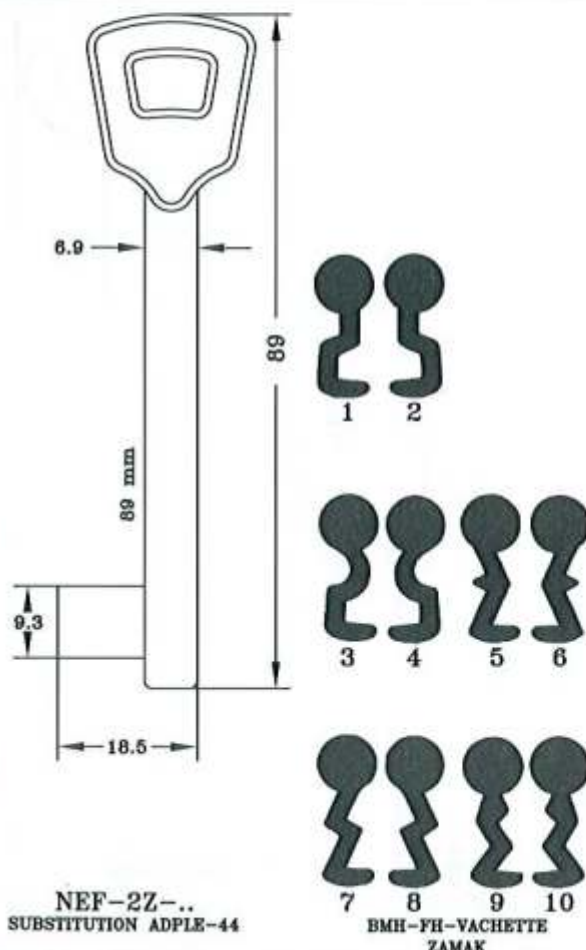
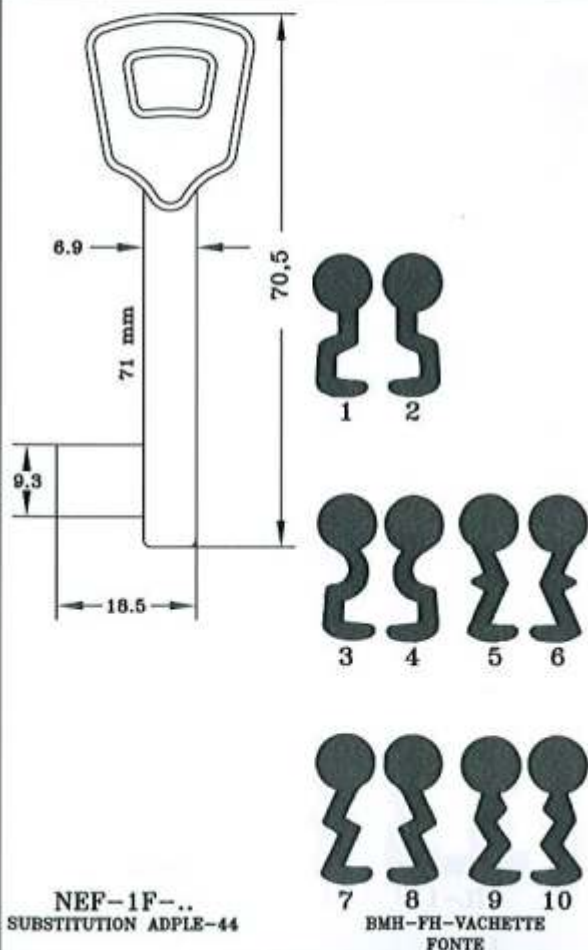

Copyright by  
Alejandro Altuna S.A.  
2011

**JMA**

POUR:

### RUBIS

RUBIS (F)

SE (F)

SELECT (F)

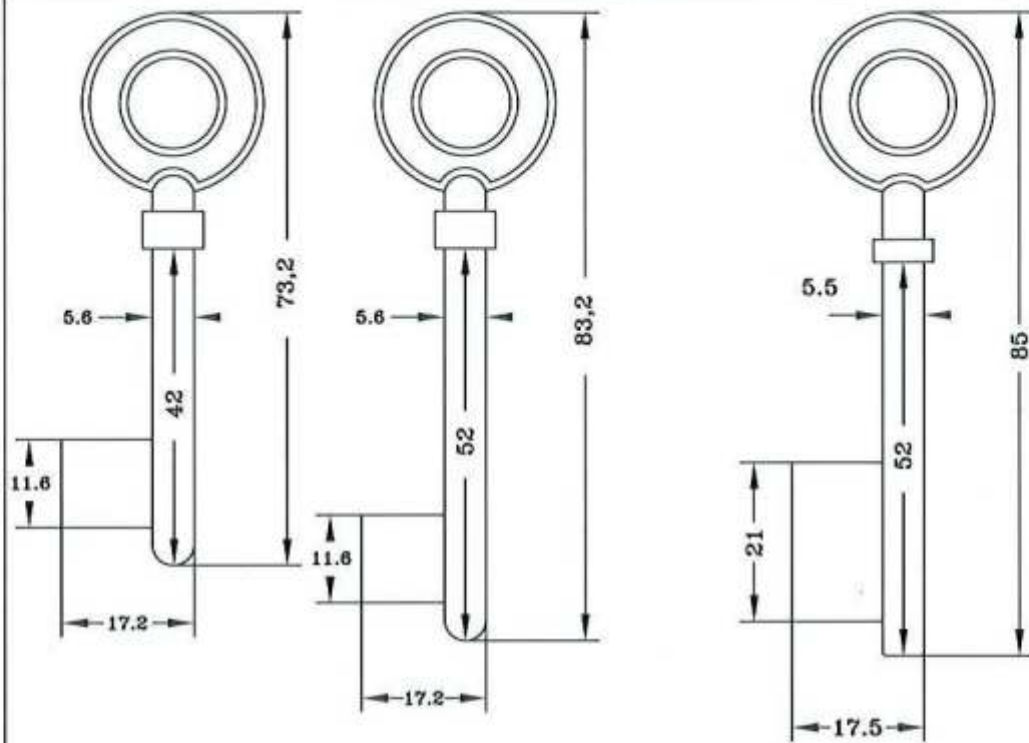

REPLACABLE PAR LA AD-45



RUB-1

LAITON



RUB-7

LAITON



AD-45

### SE

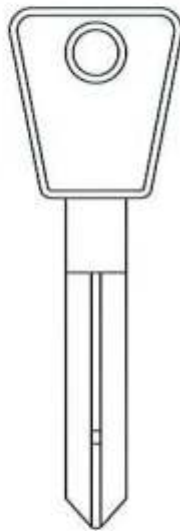

SE-1X

ZAMAK

### SELECT

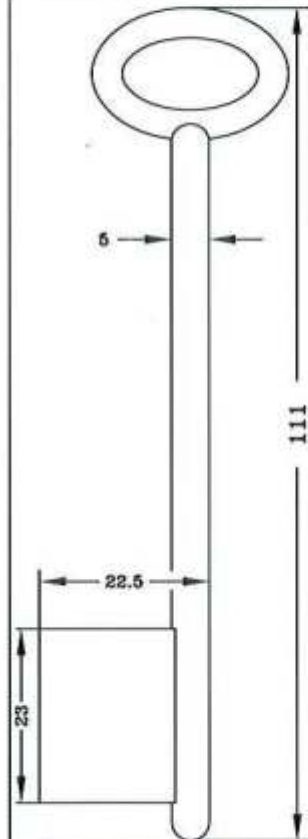

21G

LAITON

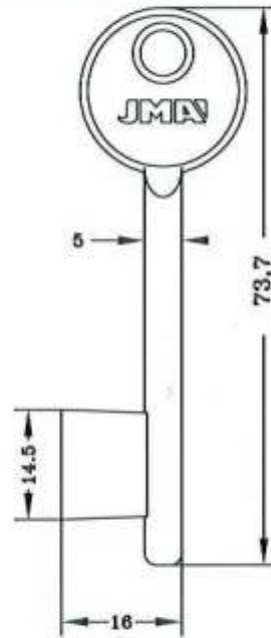

SEL-1

LAITON

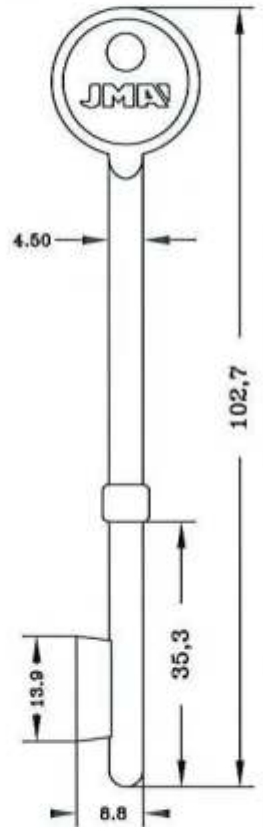

SEL-3L

LAITON

Copyright by  
Alejandro Altuna S.A.  
2011

**JMA**

43

POUR: \_\_\_\_\_

SESA (F)

### SESA

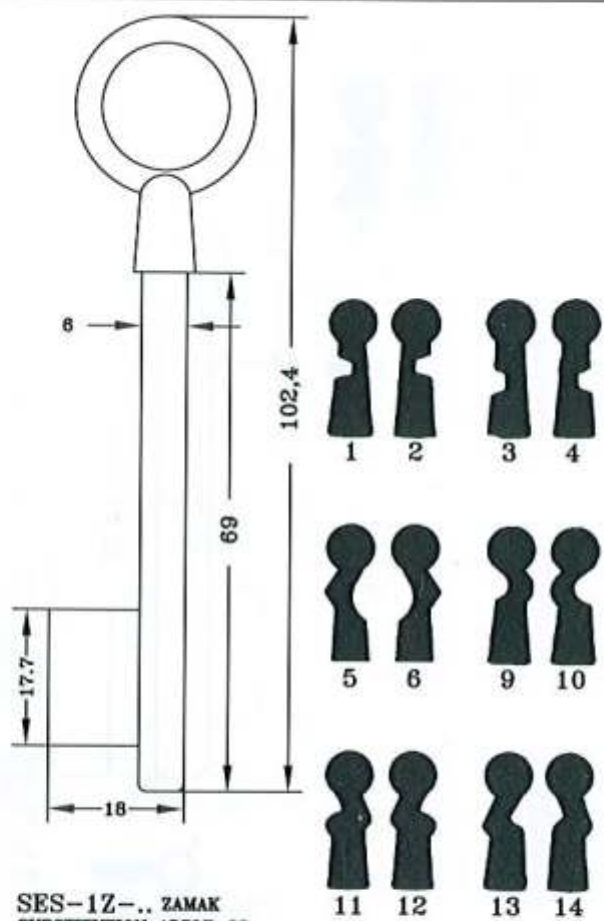

SES-1Z-.. ZAMAK  
SUBSTITUTION ADPLE-22

### SESA

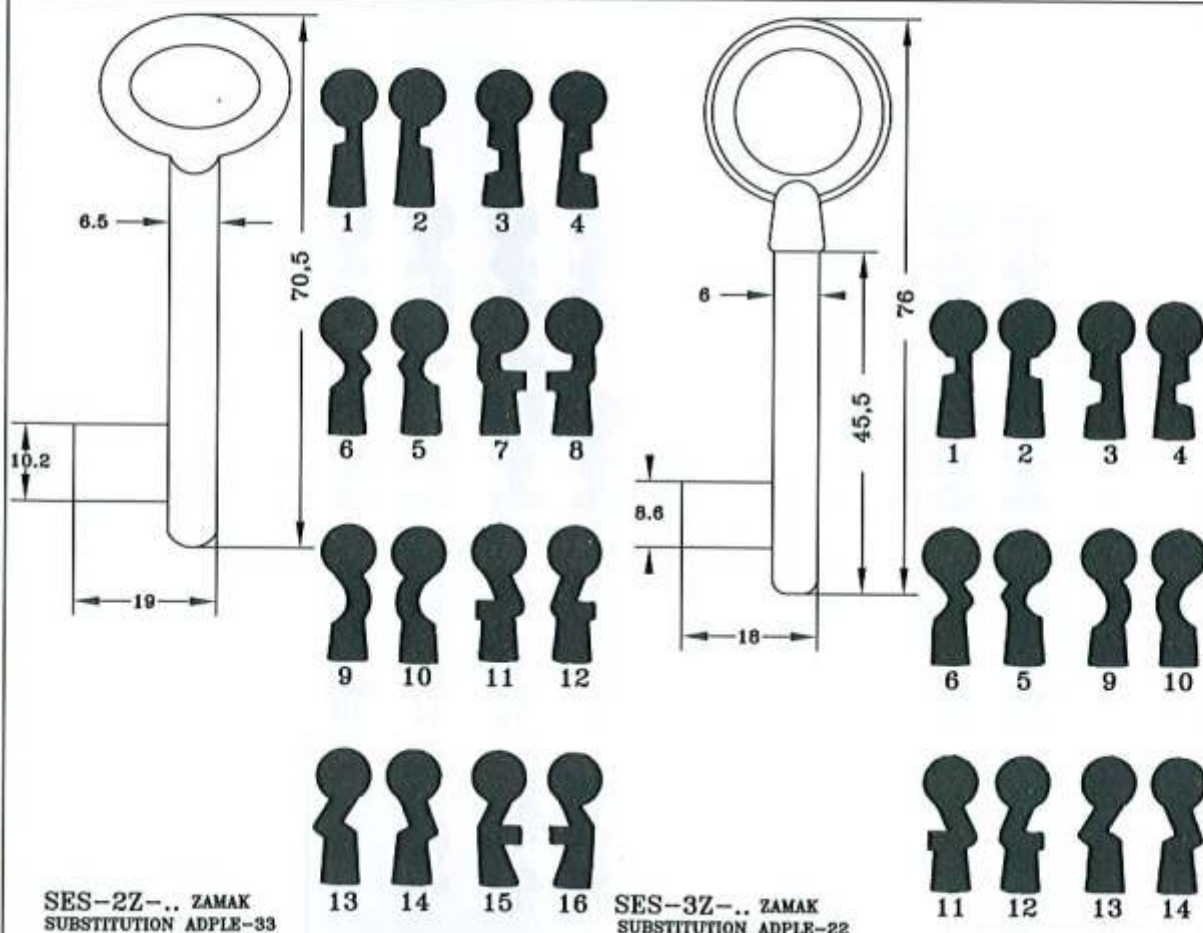

SES-2Z-.. ZAMAK  
SUBSTITUTION ADPLE-33

SES-3Z-.. ZAMAK  
SUBSTITUTION ADPLE-22

Copyright by  
Alejandro Altuna S.A.  
2011

# JMA

POUR:

STREMLER

STREMLER (F)

STUV (D)

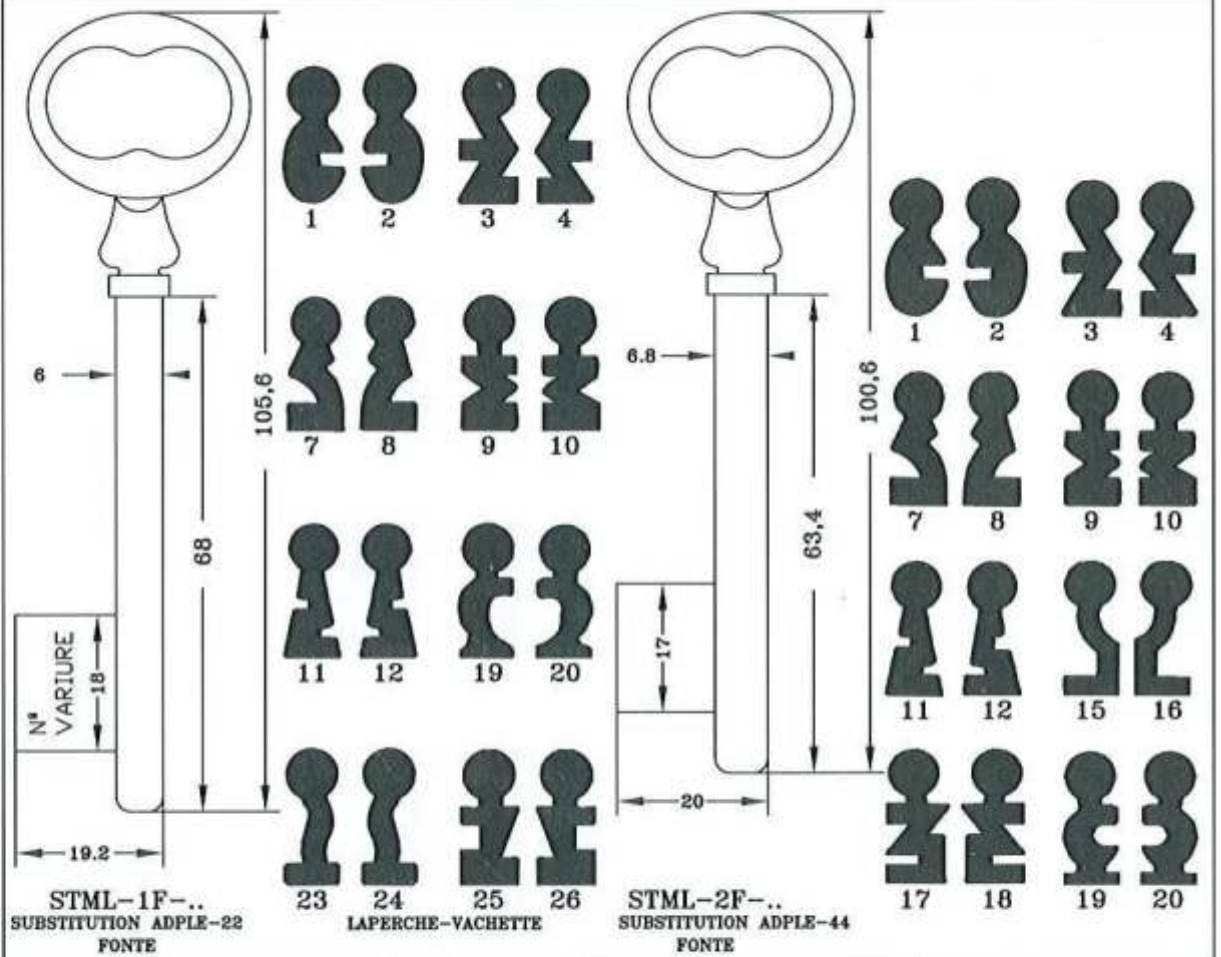

STREMLER

STUV

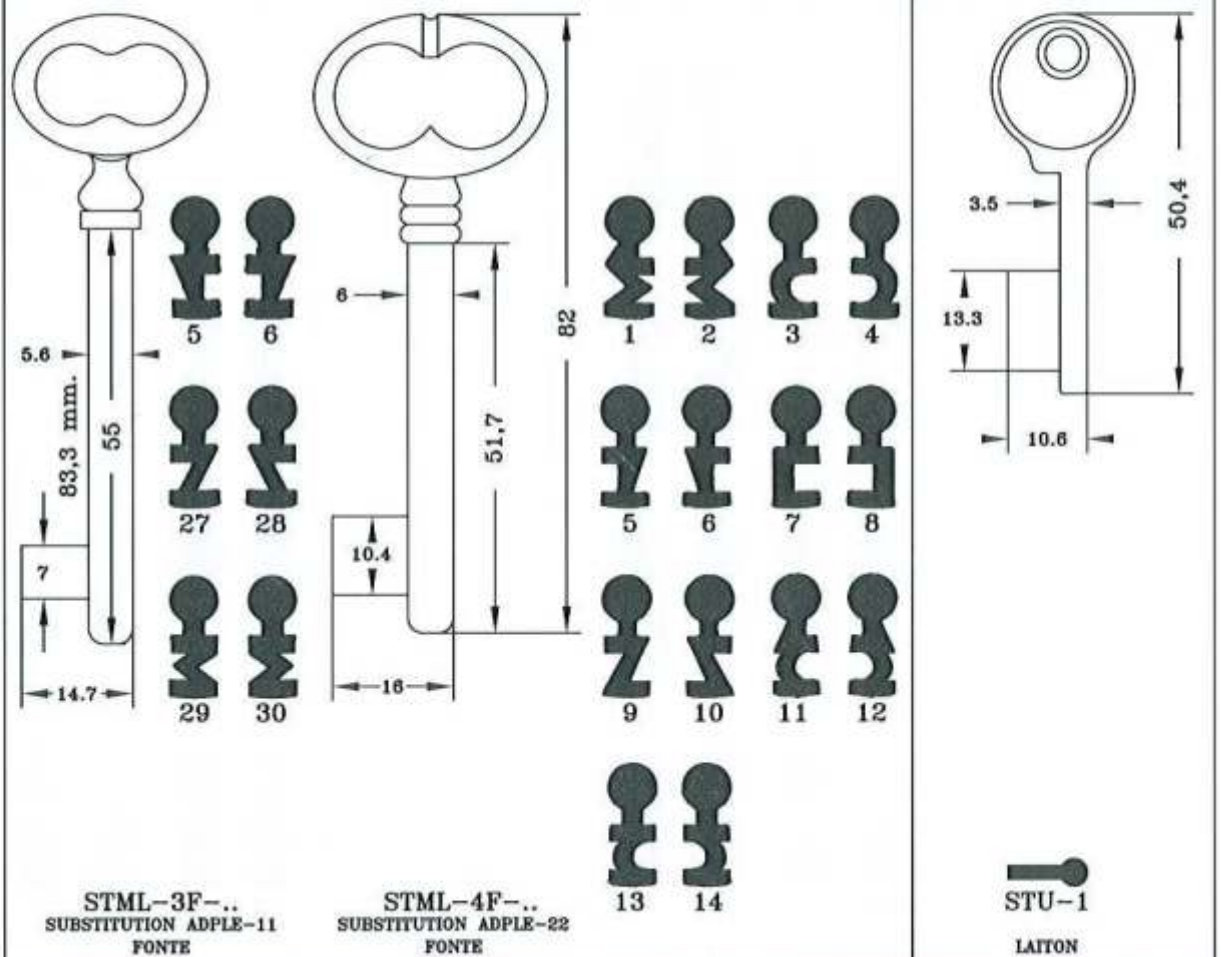

Copyright by  
Alejandro Altuna S.A.  
2011

**JMA**

45

## VACHETTE

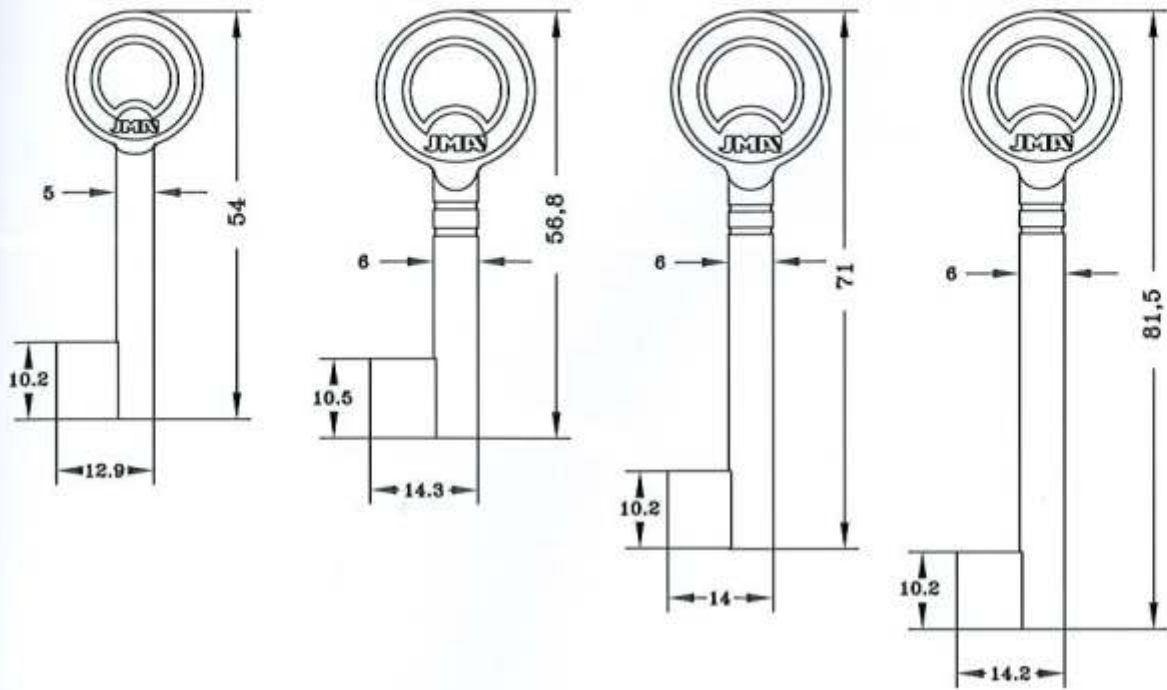

## VACHETTE

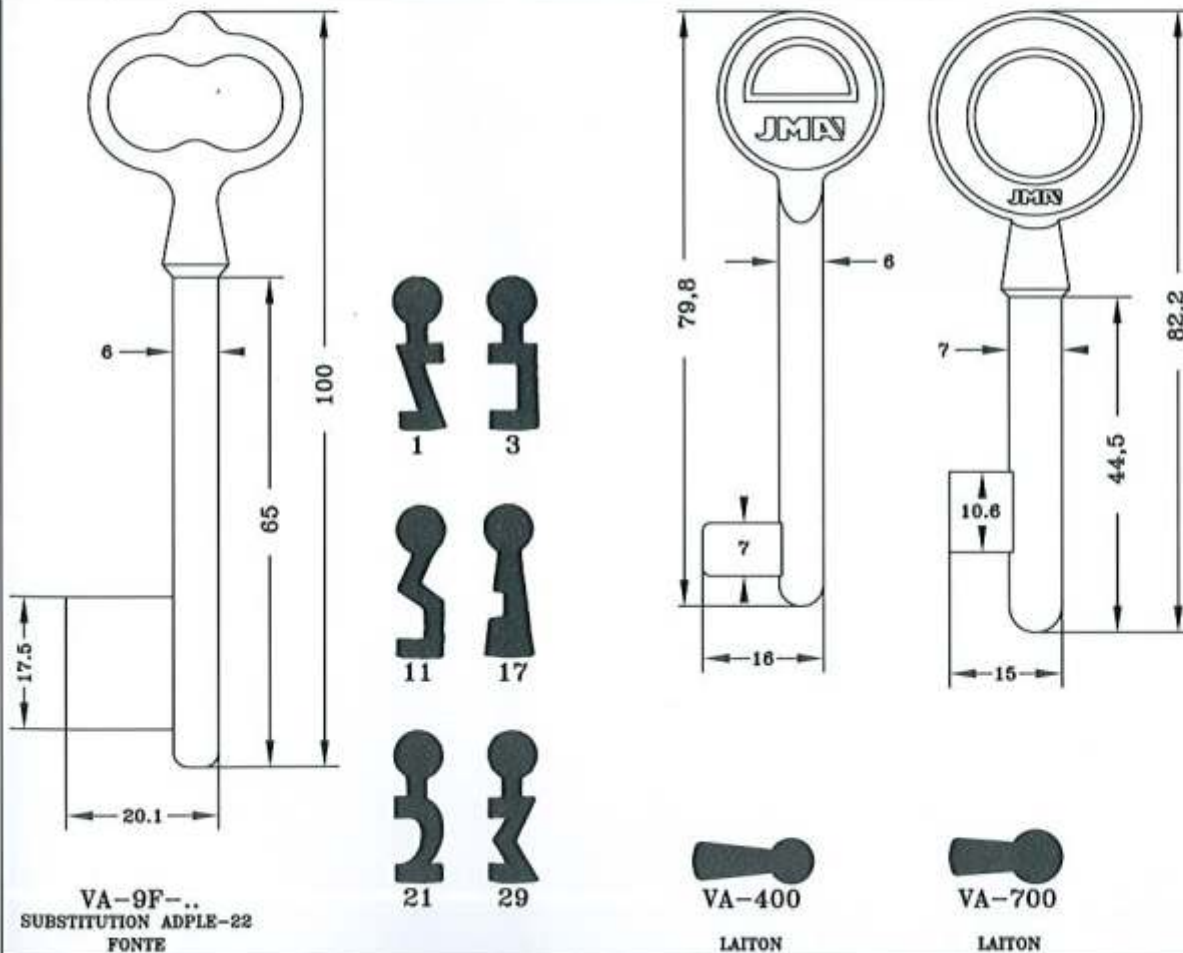

POUR:  
VACHETTE (F)

Copyright by  
Alejandro Altuna S.A.  
2011

**JMA**

**46**

**CLES DE STYLE POUR MEUBLES**



**THE KEY TO EXCELLENCE**  
GLOBALLY UNLOCKING MILLIONS OF DOORS DAILY

POUR:

### CLES DE STYLE POUR MEUBLES - EN FONTE

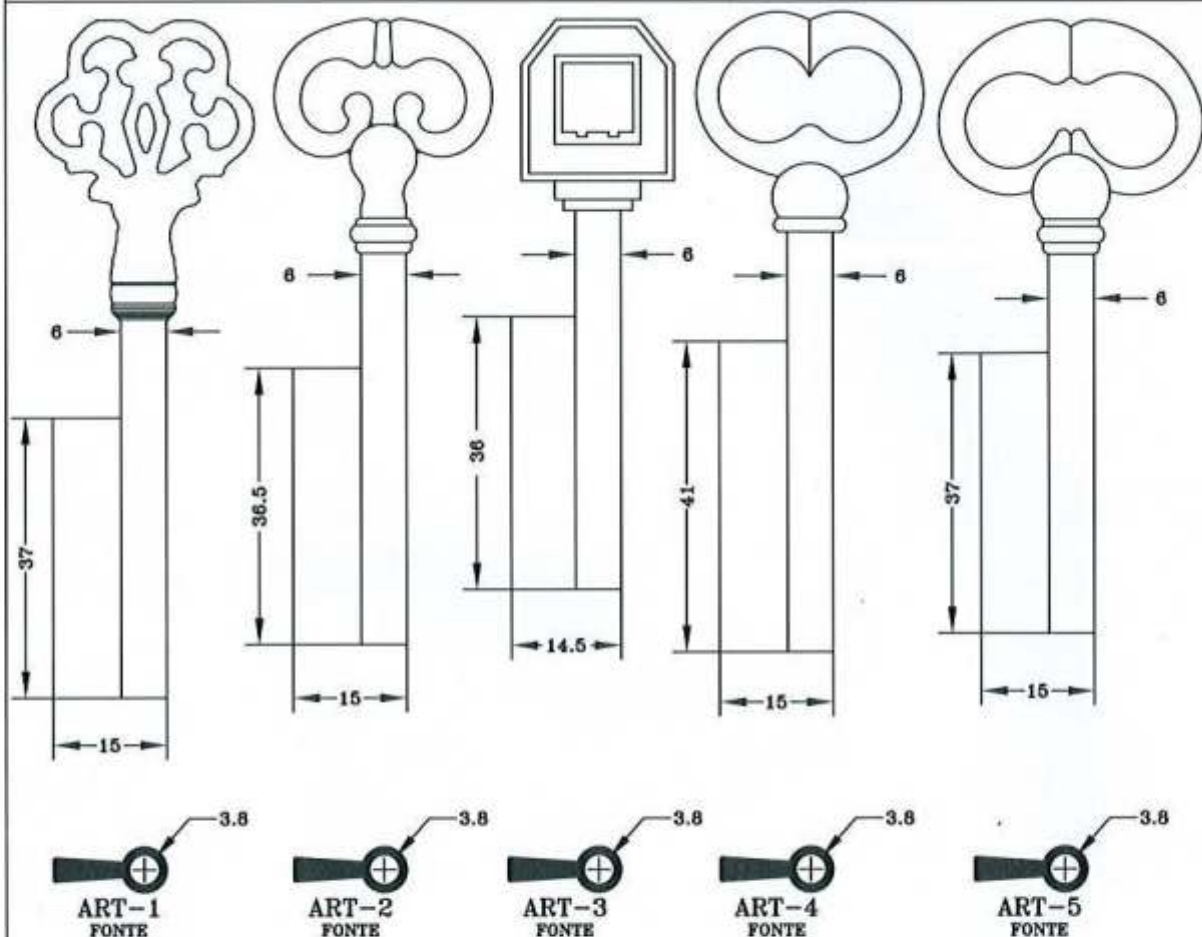

### CLES DE STYLE POUR MEUBLES - EN LAITON

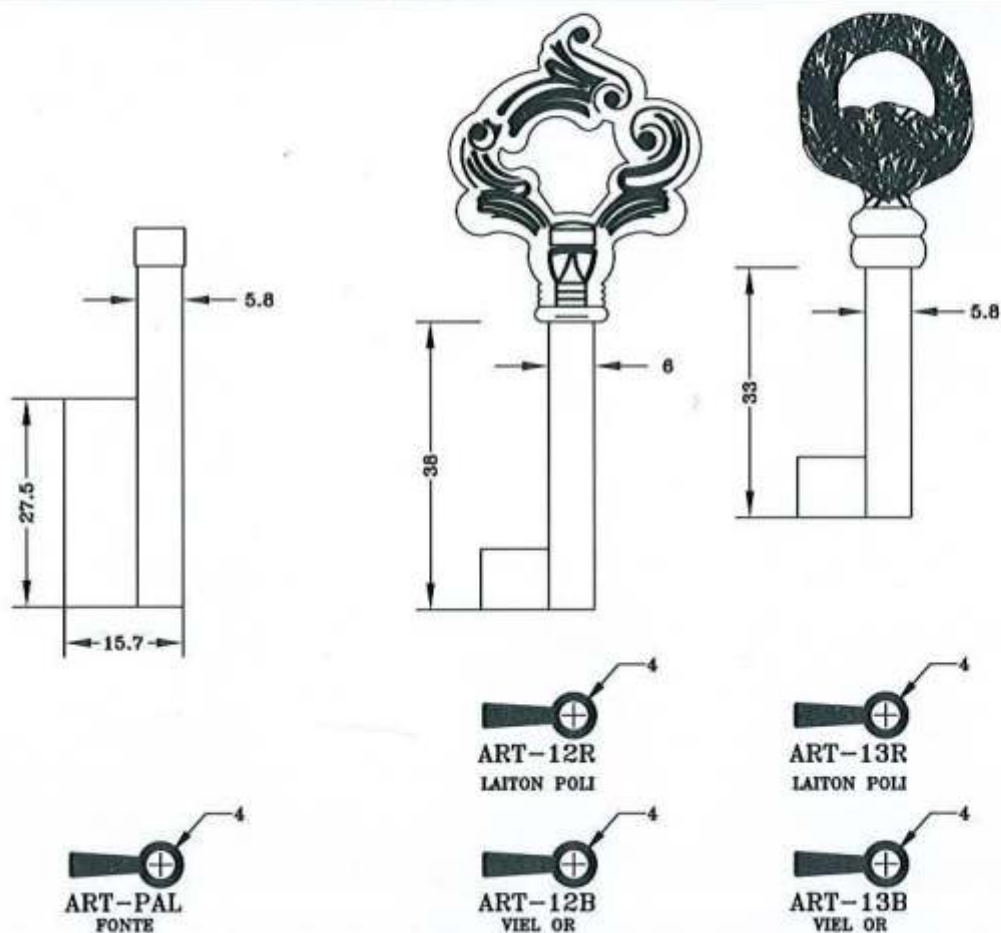

Copyright by  
Alejandro Altuna S.A.  
2011

**JMA**

49

## CLES DE STYLE POUR MEUBLES - EN LAITON

POUR: \_\_\_\_\_

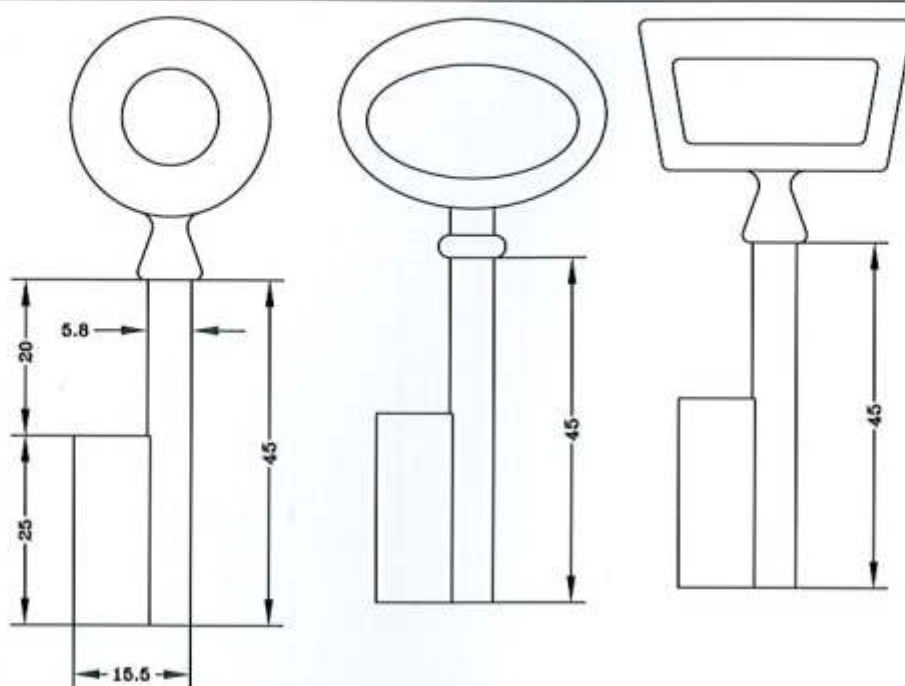

LAITON POLI	B-3G
VIEIL OR	B-3G CV

LAITON POLI	C-3G
VIEIL OR	C-3G CV

LAITON POLI	H-3G
VIEIL OR	H-3G CV

PERMETTENT DE COPIER DES CLÉS AVEC UNE CANNE DE LONGUEUR 30,35,40,45 mm, ET PANNETON DE HAUTEUR 10 mm

## CLES DE STYLE POUR MEUBLES - EN LAITON

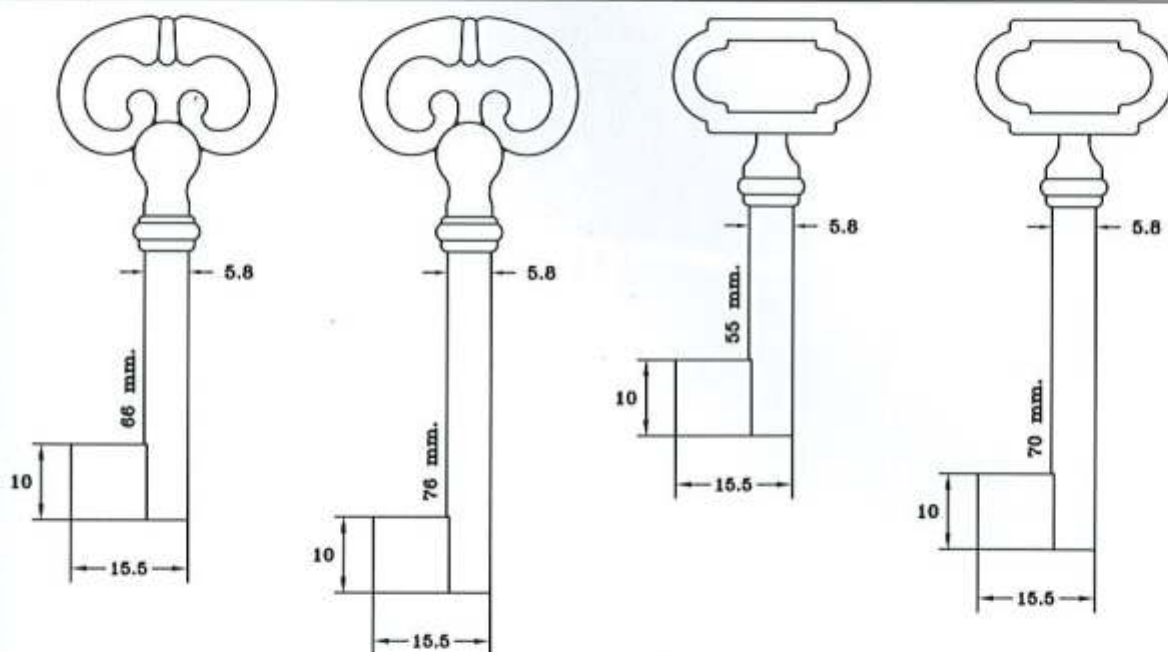

Copyright by  
Alejandro Altuna S.A.  
2011

**JMA**

50

POUR:

CLES DE STYLE POUR MEUBLES - EN LAITON

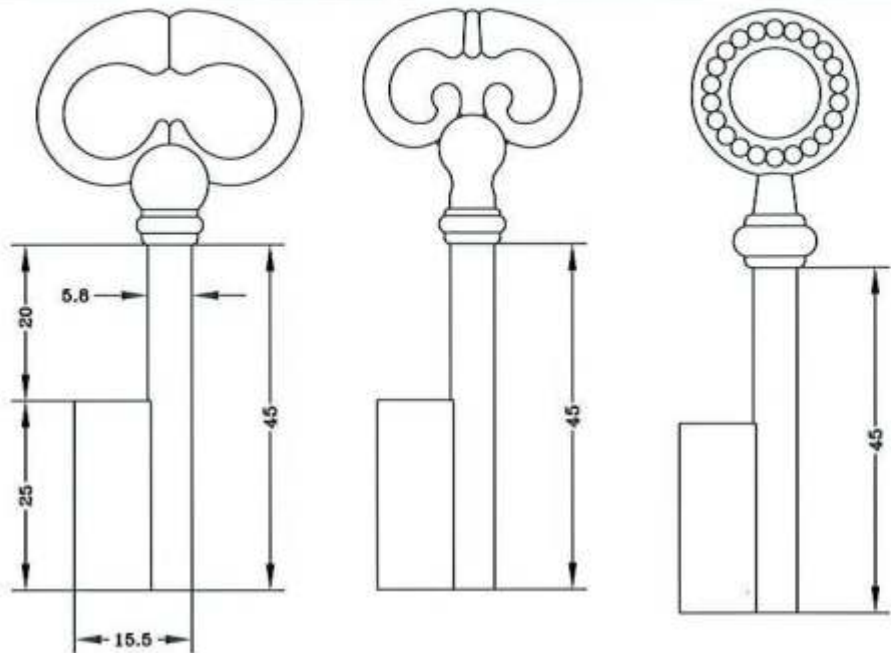

LAITON POLI	L-3G
VIEIL OR	L-3G CV

LAITON POLI	J-3G
VIEIL OR	J-3G CV

LAITON POLI	AA-3G
VIEIL OR	AA-3G CV

PERMETTENT DE COPIER DES CLÉS AVEC UNE CANNE DE LONGUEUR 30,35,40,45 mm, ET PANNETON DE HAUTEUR 10 mm

CLES DE STYLE POUR MEUBLES - EN LAITON

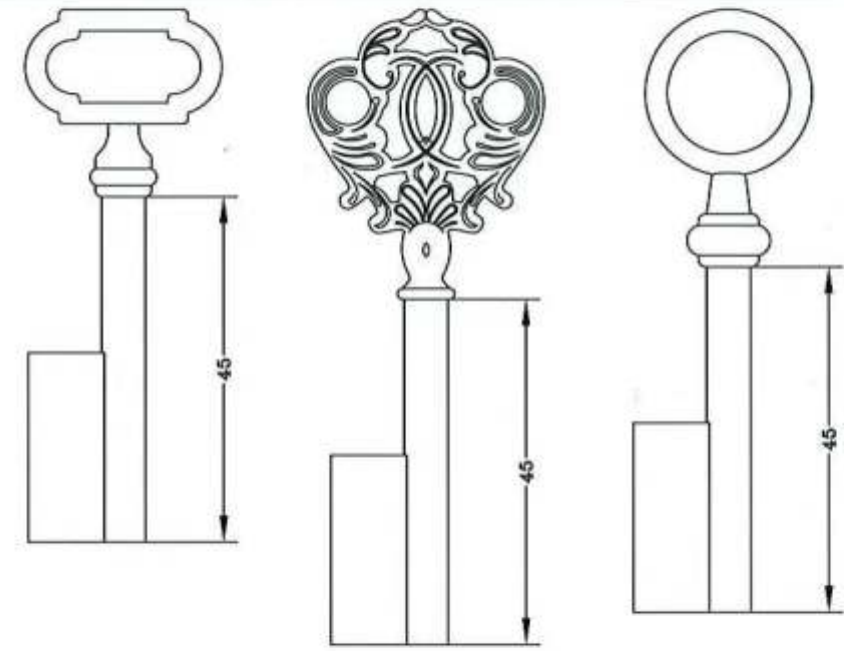

LAITON POLI	V-3G
VIEIL OR	V-3G CV

LAITON POLI	E-3G
VIEIL OR	E-3G CV

LAITON POLI	A-3G
VIEIL OR	A-3G CV

PERMETTENT DE COPIER DES CLÉS AVEC UNE CANNE DE LONGUEUR 30,35,40,45 mm, ET PANNETON DE HAUTEUR 10 mm

Copyright by Alejandro Altuna S.A. 2011



ATTENTION: Concernant les marques et dénominations commerciales voir la note dans l'index.

***CLES POUR ASCENSEURS ET BOITES AUX LETTRES***

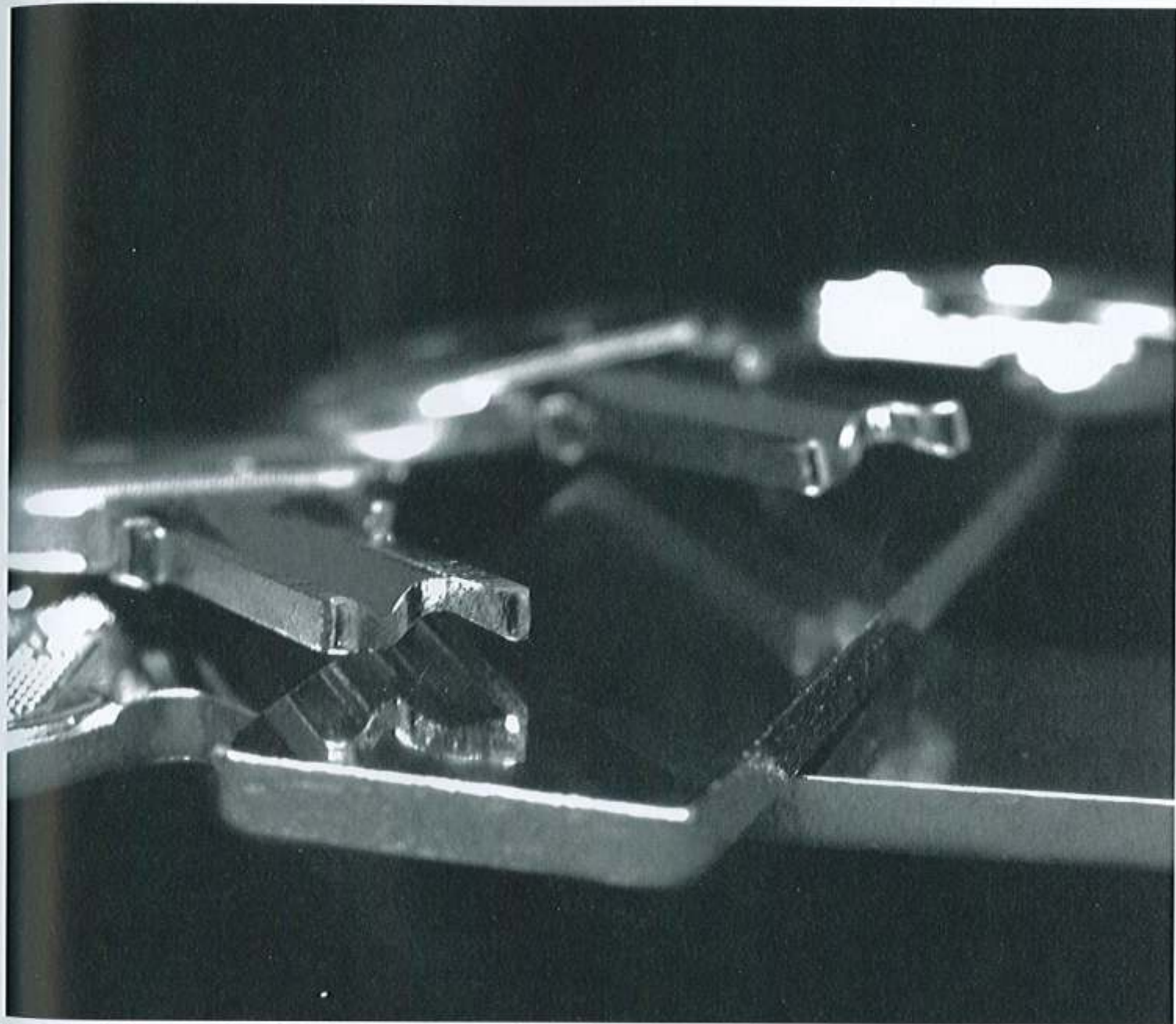

***THE KEY TO EXCELLENCE***  
*GLOBALY UNLOCKING MILLIONS OF DOORS DAILY*

POUR:

CLES PLATES ACIER (DIVERSES)

MUEL(F)

RIL (E)

VACHETTE (F)

YALE (GB)

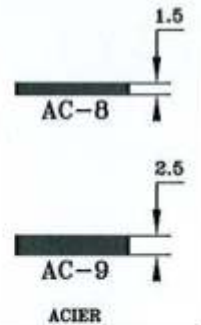
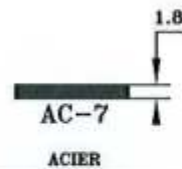
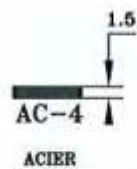
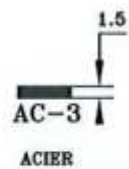
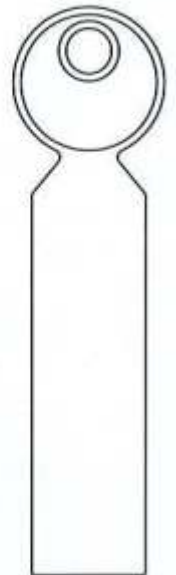
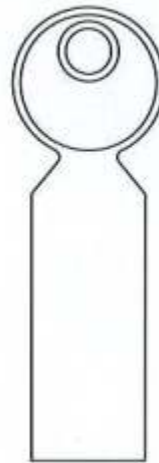
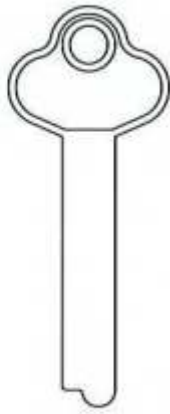

MUEL

RIL

VACHETTE

YALE

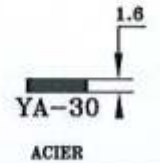
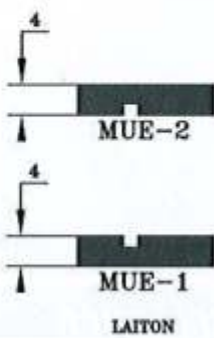
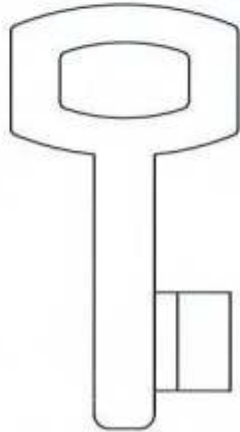

Copyright by  
Alejandro Altuna S.A.  
2011

**JMA**

53

***CLES POUR COFFRES-FORTS FRANÇAIS***



***THE KEY TO EXCELLENCE***  
*GLOBALY UNLOCKING MILLIONS OF DOORS DAILY*

**POUR:**

**DUCERF**

**DUCERF (F)**

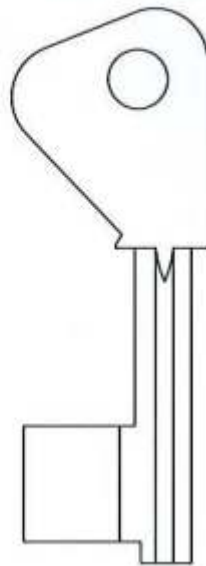

**FICHET- NS (F)**



**DUC-2**



**DUC-1**

**ACIER**

**FICHET-NS**

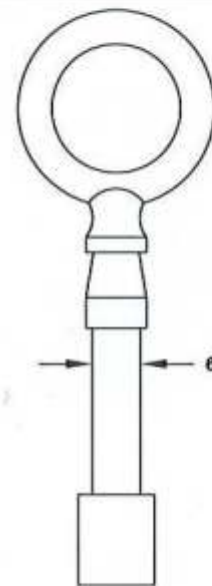
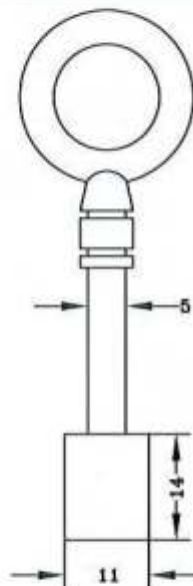
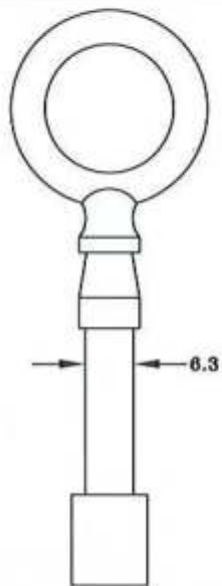

**FIC-1 NS**

**ACIER**



**FIC-2 NS**

**ACIER**



**FIC-3 NS**

**ACIER**

Copyright by  
Alejandro Altuna S.A.  
2011

**JMA**

**55**

# FICHET-BAUCHE

POUR:

FICHET  
BAUCHE (F)

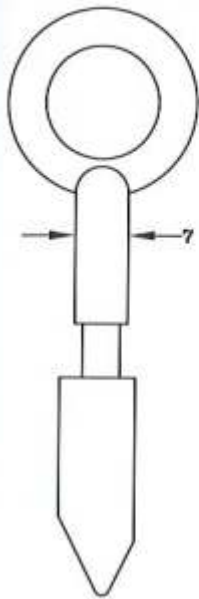

  
FIC-1X  
ACIER



  
FIC-2X  
ACIER

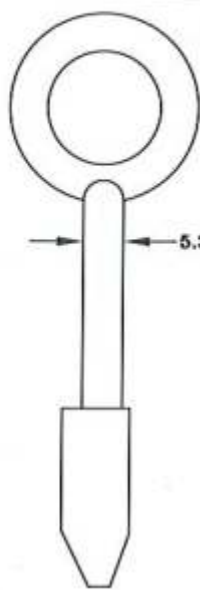

  
FIC-3X  
ACIER

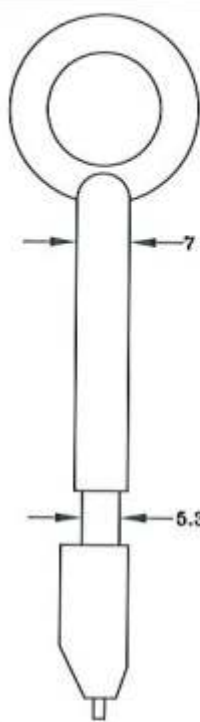

  
FIC-4X  
ACIER

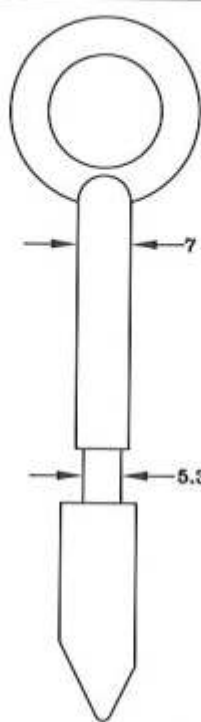

  
FIC-5X  
ACIER

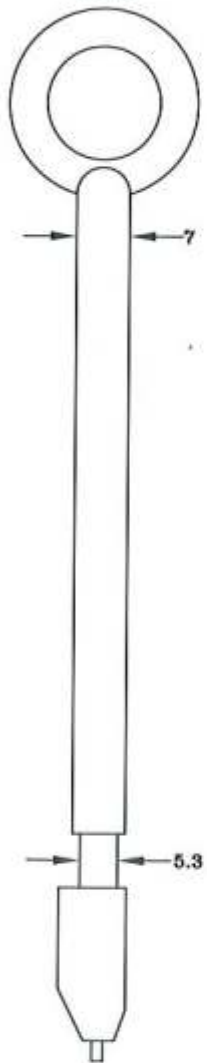

  
FIC-6X  
ACIER

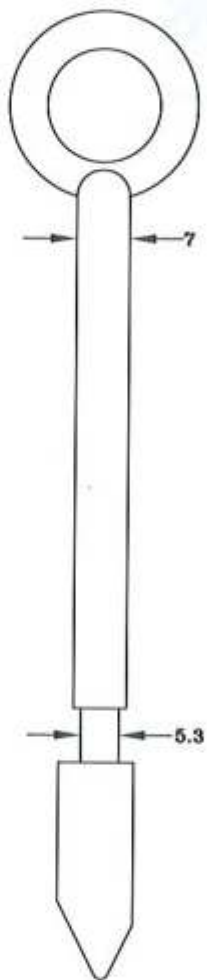

  
FIC-7X  
ACIER

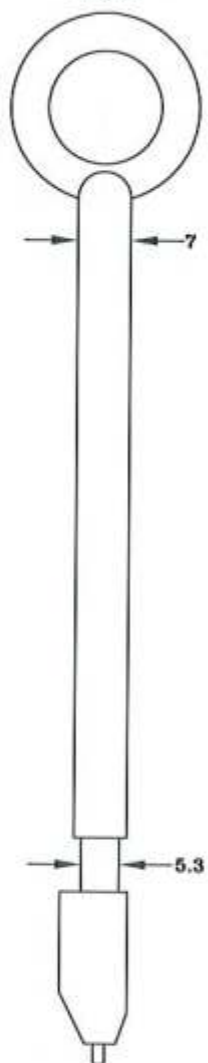

  
FIC-8X  
ACIER

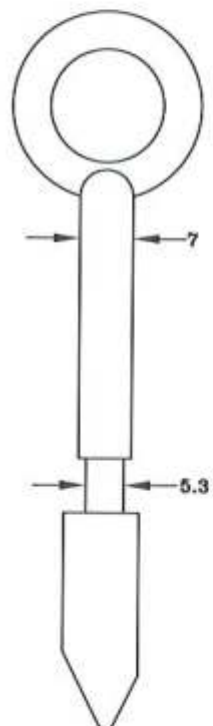

  
FIC-9X  
ACIER

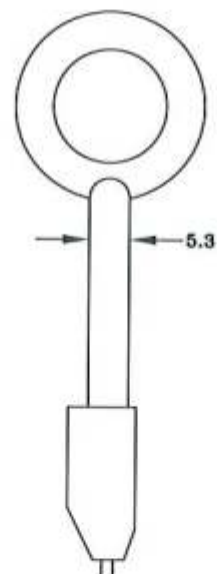

  
FIC-10X  
ACIER

Copyright by  
Alejandro Altuna S.A.  
2011

**JMA**

56

POUR:

# FICHET-BAUCHE

FICHET  
BAUCHE (F)

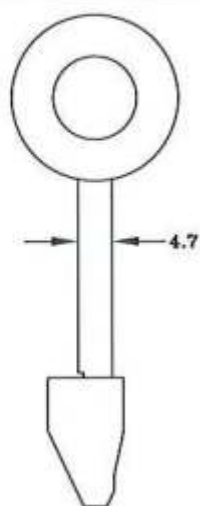

  
FIC-11X  
ACIER

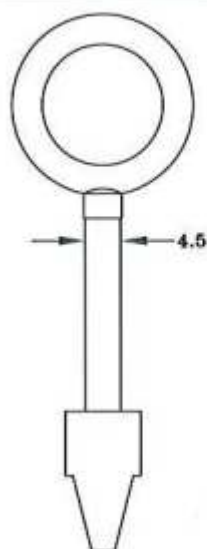

  
FIC-12X  
ACIER

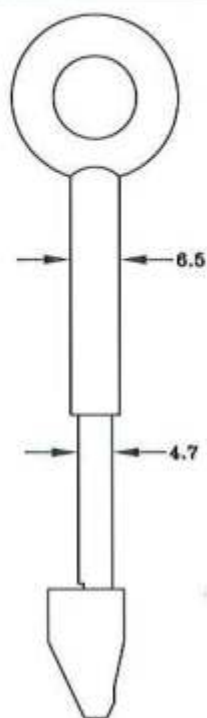

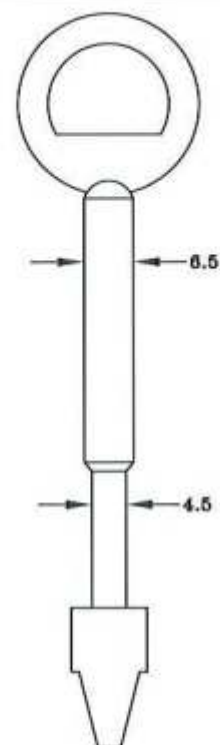

  
FIC-13X  
ACIER

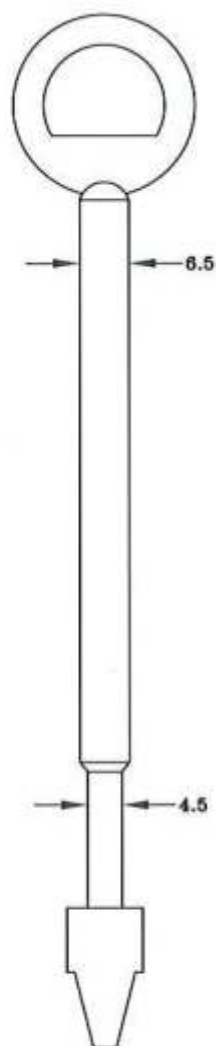

  
FIC-15X  
ACIER



  
FIC-16X

  
FIC-17X

ACIER

Copyright by  
Alejandro Altuna S.A.  
2011

**JMA**

57

POUR:

NUGUE (F)

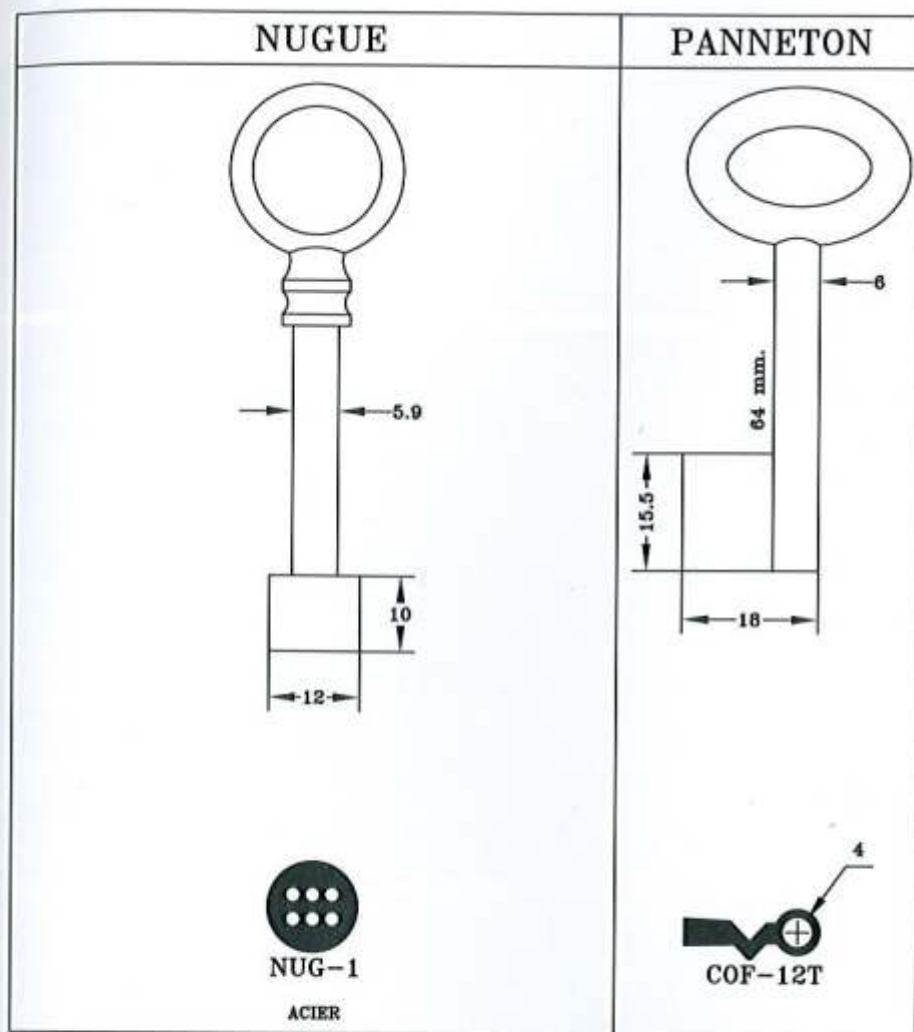

Copyright by  
Alejandro Altuna S.A.  
2011

**JMA**

**58**

**CLÉS SPECIALES**

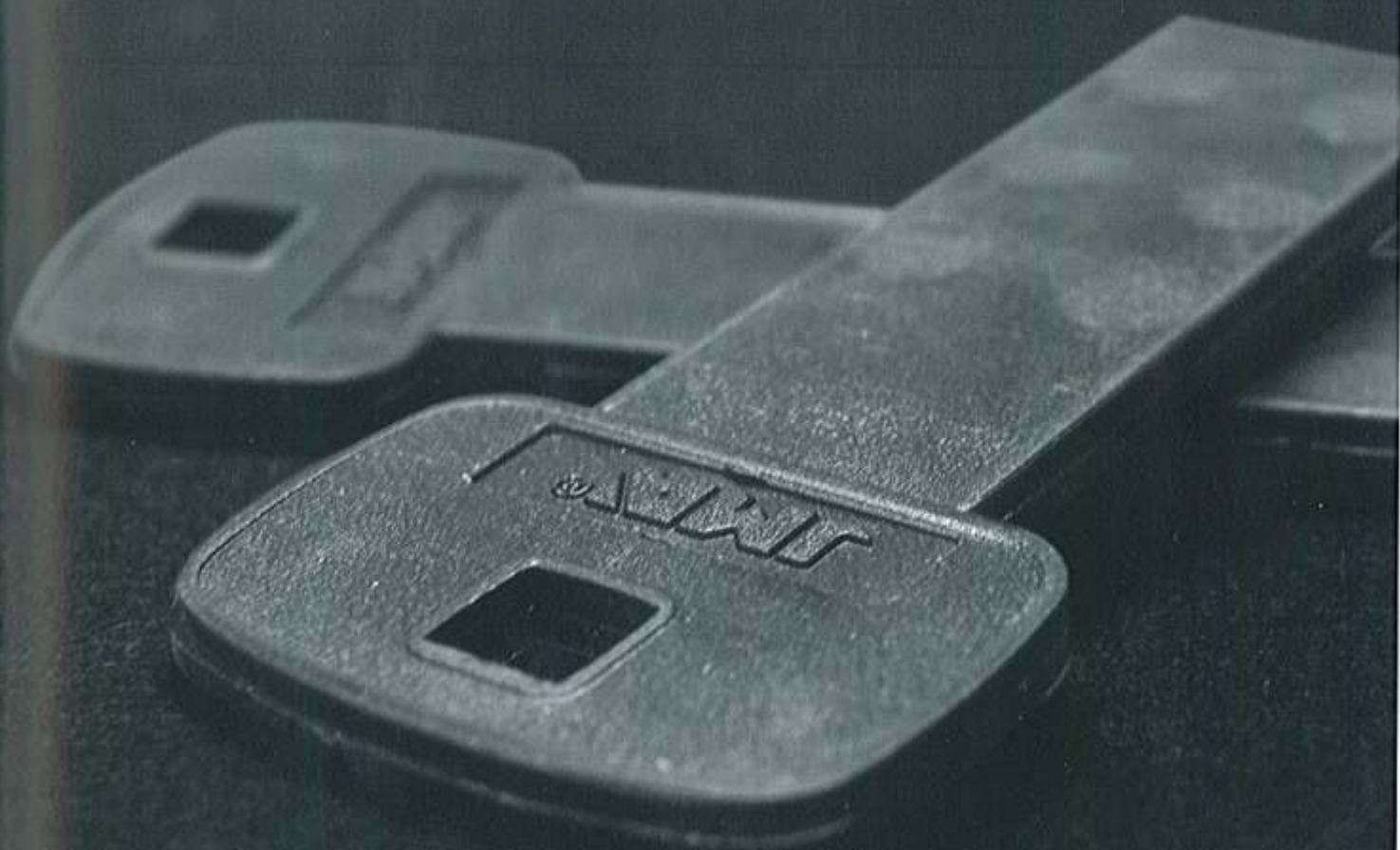

**THE KEY TO EXCELLENCE**  
GLOBALLY UNLOCKING MILLIONS OF DOORS DAILY









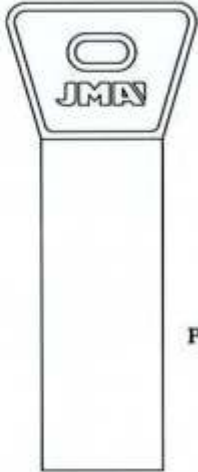

**POUR:**

CELINSA (E)

RONIS (F)

STS (E)

TESA (E)

	CELINSA	RONIS	STS	TESA
				
	PLAS.		ALP.	
	 MG-6S CEL	 RO-35.P	1 AL 7 1 AL 3 MODA  STS-T15  STS-T10A PICARDIE-TESA	 TE-8DKT  TE-8DKT1

Copyright by  
Alejandro Altuna S.A.  
2011

**JMA**

61

**PAL** SERVICE  
MINUTE

Tél. 04 73 84 84 94